

The avian heart is divided into four complete chambers and is located midway in the thoracic cavity in an indentation in the sternum parallel to the long axis of the body.^{50,91} The right atrioventricular (AV) valve is a simple muscular flap devoid of chordae tendineae, while the left bicuspid AV valve is thin and membranous. Both the aortic and pulmonary valves are membranous and tricuspid as in mammals. The left ventricle is heavily walled and is about two to three times thicker than the right. The right ventricle works as a volume pump and responds rapidly to an increased workload by dilation and hypertrophy.⁴⁸ Rigor mortis in a normal heart always results in complete emptying of the left ventricle. Rigor mortis may not occur if severe degenerative disease of the myocardium is present.³¹

In contrast to mammals, in which the lungs are situated on either side of the heart, the apex of the avian heart is covered ventrally by the cranial portion of the right and left liver lobes (see Color 14). The normal pericardial sac is clear and in contact with the epicardium circumferentially and the mediastinal pleura dorsally (see Color 13). A normal bird should have a small quantity of clear to slightly yellow fluid in the pericardial sac (see Color 14). The muscle fibers in the avian heart are five to ten times smaller than the muscle fibers in mammals, and their internal structure is simple, lacking the T-tubules found in mammals. The small surface area precludes the need for a complex T-tubule system for excitation to occur. The heart is normally even in color and is deep reddish-tan (see Color 14). In neonates, the heart is normally a lighter pink color and may appear pale.

CHAPTER

27

CARDIOLOGY

J. T. Lumeij
Branson W. Ritchie

Birds have a proportionately larger heart (1.4 to 2 times larger), higher pulse rate, higher blood pressure and a slightly lower peripheral resistance to blood flow than is found in mammals. These factors contribute to the enhanced circulatory and oxygen transport systems that are necessary to sustain flight. The increased cardiac output requires a higher arterial pressure to produce higher blood flow rates. High blood pressure is a predisposing factor to aneurysm and aortic rupture in male turkeys of hypertensive strains.^{53,54} On a body weight basis, smaller birds in general have a bigger heart than larger birds. Systolic blood pressure ranges from 108 to 220 mm Hg depending on the species.

The aorta in birds is derived embryologically from the right fourth arterial arch and right dorsal aorta and therefore the ascending aorta curves to the right and not to the left as in mammals. This structure can be clearly seen radiographically on a ventrodorsal projection. Blood is returned to the heart from the peripheral circulation by the left and right cranial caval veins and a single caudal caval vein. Most of the myocardial blood supply comes from deep branches of the right and left coronary arteries.



Evaluating the Avian Heart

■ Electrophysiology⁸⁷

The electrocardiogram (ECG) reflects the differences in conduction that occur between the avian and mammalian heart. Electrical impulses that precede mechanical contraction of the myocardium are generated in the sinoatrial (SA) node. Because the rate of depolarization of the cells of the SA node is higher than that of any other cardiac muscle cell, the SA node functions normally as the cardiac pacemaker. The SA node is located between the entrance of the right cranial vena cava and the caudal vena cava into the right atrium. Electrical impulses are transported along ordinary muscle fibers in the interatrial septum to the atrioventricular (AV) node. The P-wave in the ECG depicts this part of the electrical conduction (ie, depolarization of the atria).

The AV node is located in the caudoventral part of the interatrial septum or the caudodorsal part of the interventricular septum. Electrical conduction is de-

layed in the AV node, which facilitates filling of the ventricles before they contract. Delay of conduction in the AV node is depicted by the PR-segment in the ECG. The AV node is continuous with the AV bundle branches into right and left crura as it courses into the interventricular septum. The AV bundle electrically separates the atria from the ventricles by penetrating the fibrous tissue. The AV node in birds also gives rise to the right AV ring that encircles the right AV opening and controls the activity of the right muscular AV valve. There are also fibers running to the truncobulbar node at the base of the aorta.

The AV bundles and their branches consist of Purkinje fibers. Electrical conduction in Purkinje fibers is about five times faster than in normal cardiac muscle cells and hence the conduction system plays an important role in regulating myocardial contraction. After transmission of the electrical impulses through the ventricular conduction system, all areas of the ventricles are activated in a coordinated fashion. Depolarization of the ventricles is depicted by the QRS complex in the ECG.

Birds have a mean electrical axis that is negative, while the mean electrical axis in dogs is positive. This difference can be explained by the fact that in birds, the depolarization wave of the ventricles begins subepicardially and spreads through the myocardium to the endocardium, while in the dog, depolarization of the ventricles starts subendocardially. The parasympathetic nervous system (via the vagus nerve) and the sympathetic nervous system (via the cardiac nerve) synapse on the SA node.

■ Diagnostic Methods

Primary heart diseases should be included in the differential diagnosis when avian patients are presented with lethargy, periodic weakness, dyspnea, coughing and abdominal swelling (ascites). Any drugs that the patient has received, potential exposure to toxins and concurrent diseases should always be evaluated when determining if the heart is abnormal. Arteriovascular disease was noted in 199 of 1726 mixed avian species necropsied in one zoological collection.¹³ Cardiac-induced ascites appears to be less common in Psittaciformes than in Galliformes and Anseriformes.

Auscultation of the avian heart is difficult and the information that can be gained is limited. Subtle murmurs are easiest to detect when birds are under isoflurane anesthesia and the heart rate is de-

creased. Auscultation of the heart can best be performed on the left and right ventral thorax. Pleural or pulmonary fluid accumulation may cause muffled lung sounds or rales when a bird is auscultated over the back between the shoulder blades.

Mild stress, such as occurs in the veterinary examination room or following restraint, may cause a bird's heart rate to increase substantially (two to three times normal). Exercise, age, climatic conditions, stress factors, drug exposure, toxins, diet, percent body fat and blood pressure can all alter the avian heart rate. As a rule, the heart rate in a bird that is being restrained is higher than the heart rate obtained in the same bird if the rate had been determined using telemetry. A stress-induced increase in heart rate should resolve several minutes after the stressing factors are removed.

Diagnostic aids that have proven to be effective in evaluating cardiac diseases include CBC, plasma chemistries (eg, AST, LDH, CPK), cytologic examination of pericardial or peritoneal effusions, plasma electrolytes, blood culture, radiographs (including contrast studies such as nonselective angiocardiography), electrocardiography, cardiac ultrasonography (echocardiography) and color flow doppler. CPK activity from cardiac muscle origin (CPK-MB isoenzyme) was significantly higher in ducklings with furazolidone-induced cardiotoxicosis when compared to controls.^{99a}

Imaging

Radiographic detection of cardiovascular abnormalities may be difficult, although an enlarged cardiac silhouette or microcardia can often be visualized. Radiographic detection of an enlarged cardiac silhouette with muffled heart sounds is suggestive of pericardial effusion. An increased cardiac silhouette with normal heart sounds is suggestive of dilative heart disease.

Electrocardiography (low voltage in pericardial effusion) and ultrasonography may demonstrate free pericardial fluid. Microcardia is indicative of severe dehydration or blood loss that has resulted in hypovolemia (Figure 27.1). Other radiographic changes that suggest cardiac disease include congestion of pulmonary vessels, pulmonary edema, pleural effusion, hepatomegaly and ascites.

Non-selective angiocardiography with rapid sequence serial radiographs has been used to confirm impaired cardiac function in a racing pigeon (Figure 27.2).⁵⁷ This technique has also been used to rule out

cardiovascular shunt as the cause of severe dyspnea and hypoxia in a Blue and Gold Macaw. The procedure is performed by injecting a bolus dose of contrast medium into the catheterized basilic vein.⁹⁵

Of the imaging techniques, echocardiograms generally provide the most diagnostic information. Echocardiography was used successfully to detect valvular endocarditis on the aortic valve of a four-year-old female emu suspected of cardiac disease. Staphylococcus was isolated from the vegetative lesion, which was seen as a large mass using this technique.⁷⁰ In small birds, the echocardiographic image of the heart is best obtained by sweeping through the liver. Color flow doppler was used to demonstrate mitral regurgitation and right-sided heart failure in a mynah.⁷⁶

Electrocardiology

Using a capillary electrometer, Buchanan⁸ was the first to describe the form of the electrocardiograms in birds. She discovered that “when the mouth is to the acid (+) and the legs to the mercury (-)” the mean deflection of the QRS-complex in birds is negative and not positive as in mammals. In 1915 the first electrocardiogram of a pigeon made with a string galvanometer was published;⁴⁹ leads were connected to the neck and abdomen.

It was demonstrated in 1949 that the negative mean electrical axis of ventricular depolarization in birds occurs because the depolarization wave begins subepicardial and then spreads through the myocardium towards the endocardium.⁵¹ Sturkie⁸³⁻⁹² pioneered the use of clinical electrocardiography in birds and described the normal ECG of the chicken using standard bipolar limb leads. Of all avian species, both normal and abnormal ECGs of chicken and turkey have been best characterized. Details of the ECG of gulls,⁵¹ buzzards,²¹ parakeets and parrots¹⁰¹ have also been published.

Despite its great clinical applicability, electrocardiography has received relatively little attention from companion and aviary bird practitioners. This might be due to the scarcity of electrocardiographic reference values in companion birds. To the authors' knowledge these values have been established only in racing pigeons, African Grey Parrots and Amazon

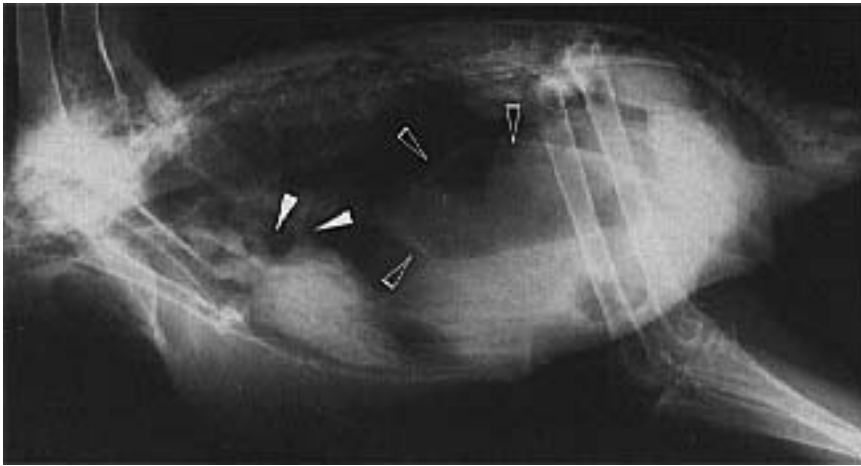

FIG 27.1 An adult Umbrella Cockatoo was presented for severe depression. The eyes were glazed and partially closed, the ulnar vein refill time was two seconds, and the skin on the toes would stay elevated for several seconds when pinched. All these findings were suggestive of severe dehydration. The lateral radiograph indicated microcardia (indicative of dehydration) and gaseous distention of the proventriculus (open arrows), which is common in birds that are anesthetized or are severely dyspneic. The pulmonary arteries and caudal vena cava are also visible (arrows). The VD view shows the gas-filled proventriculus (arrows).

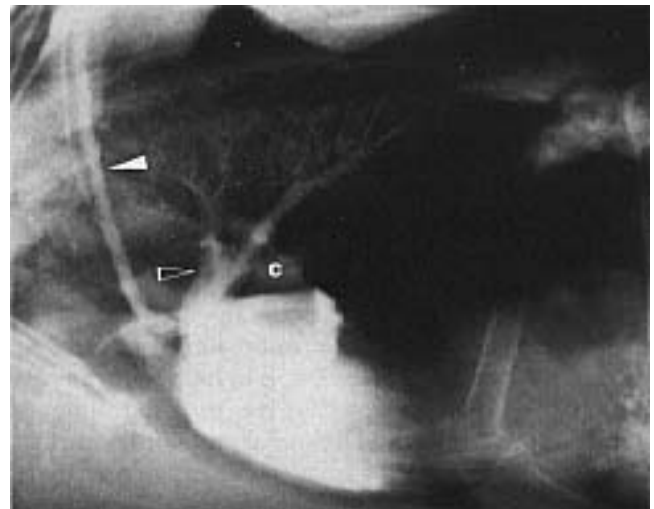

FIG 27.2 Angiography can be used to evaluate impaired cardiac function. A single rapid intravenous bolus of contrast agent was administered via a catheter into the cutaneous ulnar vein of a normal Green-winged Macaw. Images were made with a rapid film changer at six films per second. The axillary vein (arrow), cranial vena cava (c), cardiac chambers and pulmonary arteries (open arrows) are clearly visible. Note that contrast media is also present in the kidneys (courtesy of Marjorie McMillan).

TABLE 27.1 Normal Electrocardiograms in Selected Birds*

Parameter		Racing Pigeon	African Grey Parrot	Amazon Parrot
Normal heart rate		160-300	340-600	340-600
Normal heart rhythms		Normal sinus rhythm Sinus arrhythmia Second degree AV block	Normal sinus rhythm Sinus arrhythmia Ventricular premature beats Second degree AV block	
Normal heart axis		-83° to -99°	-79° to -103°	-90° to -107°
Normal measurements in lead II	P-wave duration	0.015-0.020 s	0.012-0.018 s	0.008-0.017 s
	Amplitude	0.4-0.6 mV	0.25-0.55 mV	0.25-0.60 mV
	PR-interval	0.045-0.070 s	0.040-0.055 s	0.042-0.055 s
	QRS complex duration	0.013-0.016 s	0.010-0.016 s	0.010-0.015 s
	R amplitude		0.00-0.20 mV	0.00-0.65 mV
	(Q)S amplitude	1.5-2.8 mV	0.9-2.2 mV	0.7-2.3 mV
	ST-segment	Very short or absent Elevation 0.1-0.3 mV No ST depression		
T-wave	Always discordant to the ventricular complex			
	0.3-0.8 mV	0.18-0.6 mV	0.3-0.8 mV	
QT-interval	Unanesthetized	0.060-0.075 s	0.039-0.070 s	0.038-0.055 s
	Anesthetized		0.048-0.080 s	0.050-0.095 s

*Criteria for the normal electrocardiogram in racing pigeons (n=60), African Grey Parrots (n=45) and Amazon parrots (n=37). Measurements are derived from ECGs recorded at 200 mm/s and standardized at 1 cm = 1 Mv. Reference values (inner limits of the percentiles P_{2.5} - P_{97.5} with a probability of 90%) modified from Lumeij⁶⁶ and Nap, et al.⁶⁷

parrots (Table 27.1).^{56,67} Other reports involve only a limited number of birds.

Electrocardiography may be useful for detecting cardiac enlargement from hypertrophy of any of the four cardiac chambers. Electrocardiography is indispensable for the diagnosis and treatment of cardiac arrhythmias and is also useful in monitoring changes in electrolyte concentrations during the treatment of metabolic diseases that alter electrolyte balance. When evaluating cardiac enlargement it is best to compare the electrocardiographic findings with those of cardiac imaging techniques.

The electrocardiogram may be of help in evaluating and diagnosing some of the diseases that cause vague signs of weakness, fatigue, lethargy, fever, collapse or seizures. Metabolic, cardiac, neurologic and systemic diseases that produce toxemia can cause one or all of these clinical changes. The electrocardiograph may be used also to monitor heart rate and rhythm in an anesthetized patient. Because the myocardium is very sensitive to hypoxia, the electrocardiogram can serve as a reliable indicator of the oxygenation of the bird (see Figure 27.15). The clinician should realize, however, that cardiac pathology can occur without electrocardiographic changes.

The Electrocardiograph and Recording of the ECG

Regardless of the type of electrocardiograph used, it must be able to run electrocardiograms at a paper speed of at least 100 mm/s. Avian heart rates are so rapid that inspecting and measuring the tracing is less accurate at slower speeds. For routine ECGs, the machine is standardized at 1 cm = 1 mV. When dealing with ECGs with a low voltage, the sensitivity of the machine should be doubled. If the complexes are so large that they exceed the edge of the tracing paper, the sensitivity should be halved. The calibration and the paper speed should always be marked on the electrocardiogram together with the date, time, name and case number of the patient.

The electrocardiogram can be recorded in an unanesthetized racing pigeon that is restrained in an upright position, while in parrots, isoflurane anesthesia is recommended. When comparing anesthetized and unanesthetized parrots, only the median heart rate and QT-interval were found to be significantly different ($P < 0.05$) (Table 27.1).⁶⁷

A Mingograph 62 electrocardiograph (Siemens-Elma AB) with a paper speed of 25, 100 or 200 mm/s was used by the primary author to establish the reference values listed in Table 27.1. It is easiest to perform an ECG on a bird in dorsal recumbency, but

right lateral or ventral recumbency is equally effective. Needle electrodes placed subcutaneously are superior to alligator clips for use in avian patients.^a

Lead I in birds is nearly isoelectric. The lead II electrocardiogram in Figure 27.3 is a recording of electrical currents generated during the depolarization and repolarization of the heart. The P-wave signifies that the atria have depolarized, causing contraction and ejection of their complement of blood into the ventricles. The PR-segment indicates the short delay in the atrioventricular node that occurs after the atria contract, which allows complete filling of the ventricles before ventricular contraction occurs. The depression of the initial part of the PR-segment is related to large atrial repolarization forces. In dogs, this is caused by right atrial hypertrophy and is called auricular T-wave or T_a -wave.^{5,24,96} In racing pigeons, this phenomenon is seen in 83% of healthy individuals and depicts the repolarization of the atria.⁵⁶ A “ T_a -wave” is also normal in some gallinaceous birds.⁶

In parrots, a slight indication of a T_a -wave may occasionally be noted.⁶⁷ The (Q)RS-complex represents ventricular depolarization and contraction with the ejection of blood into the aorta and pulmonary artery. The Q-wave is the first negative deflection, the R-wave is the first positive deflection and the S-wave is the first negative deflection following the R-wave. When there is no R-wave, the negative deflection is called a QS-wave. The largest wave in the QRS-complex is depicted with a capital letter, (ie, Rs or rS). The ST-segment and T-wave depict the repolarization of the ventricles. In clinically asymptomatic racing pigeons and parrots, the ST-segment is often very short or even absent, the S rising directly into the T-wave (“ST-slurring”). When the ST-segment is present, it is often elevated above the baseline (maximum 0.3 mV elevation in the racing pigeon). In mammalian species, these changes are associated with cardiac disease (ie, left ventricular hypertrophy),^{5,12} but the cause of ST-slurring in birds remains undetermined.

The duration (measured in hundredths of seconds) and amplitude (measured in millivolts) of the complexes can be measured. When the machine is standardized at 1 cm = 1 mV each small box on the vertical is 0.1 mV. When the electrocardiograph is recorded at a paper speed of 100 mm/s, each small box on the horizontal is 0.01 s and when the ECG is recorded at 200 mm/s, each small box represents 0.005 s. The

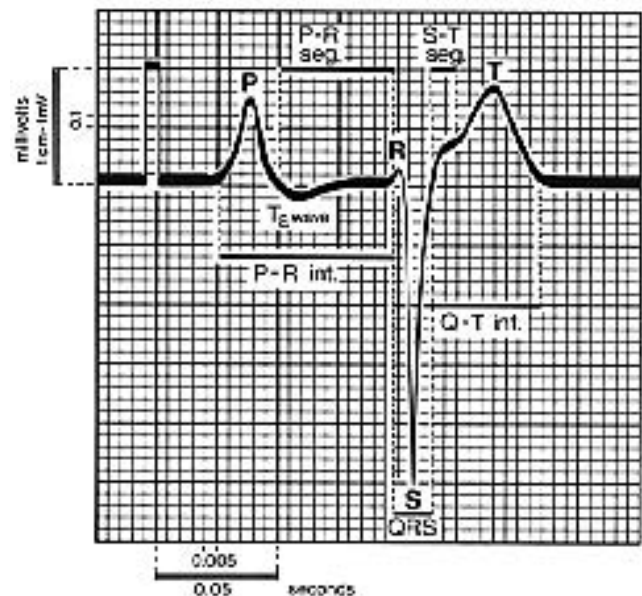

FIG 27.3 Schematic representation of a normal lead II electrocardiographic complex of a racing pigeon. Paper speed 200 mm/s, 1 cm = 1 mV (courtesy of J. T. Lumeij. Reprinted with permission⁵⁶).

determined values can be compared with reference values (Table 27.1).

ECG Leads

The vector in the frontal plane of the electrical current that is generated during ventricular depolarization is called the mean electrical axis. The various lead systems were developed to measure the direction and force of the cardiac vector accurately. Each lead has a positive and a negative pole. If an electrical impulse is traveling in the direction of a lead's negative pole, a negative deflection results and vice versa (Figure 27.4). If the vector runs perpendicular to a lead, that lead will record either no deflection or an equal number of positive and negative forces. This is called an isoelectric lead. Bailey's hexaxial lead system is most widely used in veterinary electrocardiography (Figure 27.5).^{5,24,96} It combines the three bipolar limb leads (I, II and III) from Einthoven's

CLINICAL APPLICATIONS

ECGs can be used to:

- Diagnose primary heart disease
- Monitor therapy of heart disease
- Evaluate cardiac effects of systemic abnormalities
- Monitor anesthesia
- Establish a cardiac database for the subclinical patient

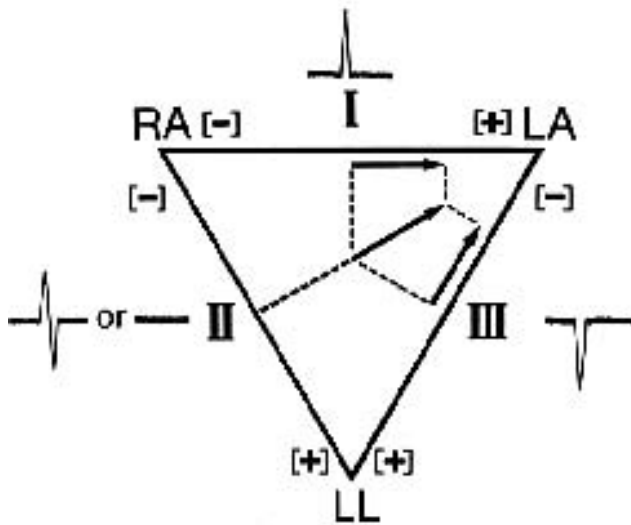

FIG 27.4 If an electrical impulse is traveling in the direction of a lead's negative pole, a negative deflection results and vice versa. If the vector runs perpendicular to a lead, that lead will record either no deflection or an equal number of positive and negative forces. This is called an isoelectric lead (see Figure 27.8).

triangle with the augmented unipolar limb leads (Figure 27.6).

The electrodes are attached to the right wing (RA), the left wing (LA) and the left limb (LL). The right hind limb (RL) of the bird is connected to the ground electrode.

- In lead I, RA is the negative pole and LA the positive pole.
- In lead II RA is the negative pole and LL is the positive pole.
- In lead III LA is the negative pole and LL is the positive pole.

In theory, these three leads form an equilateral triangle. The three leads can be redrawn exactly at the same length and polarity by passing each lead through the center point of the triangle. This produces a triaxial system, and angle values can be assigned to both the positive and negative pole of each lead.

The augmented (machine-induced increase in signal strength) unipolar leads (aVR, aVL, aVF) provide three more leads (Figure 27.6). An augmented unipolar lead compares the electrical activity of the reference limb to the sum of the electrical activity at the other limbs. The augmented vector leads are right arm (AVR), left arm (aVL) and frontal plane (aVF);

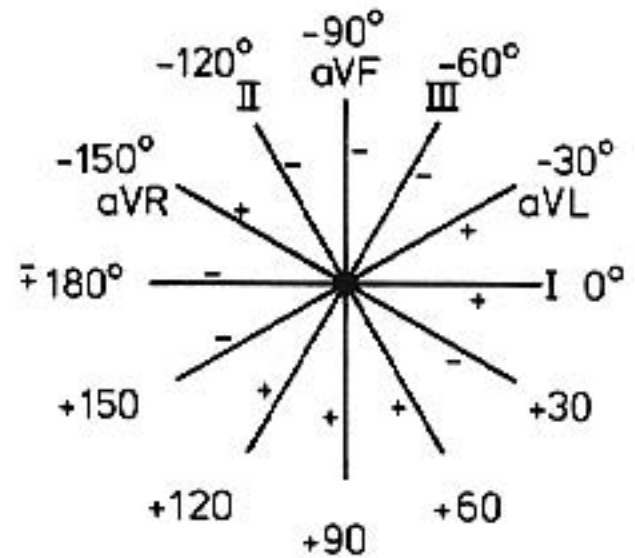

FIG 27.5 Bailey's hexaxial system. The three leads from Einthoven's triangle (I, II, III) and the three unipolar leads (aVR, aVL, aVF) can be redrawn exactly at the same length and polarity by passing each lead through the center point of the triangle. This produces a hexaxial system and angle values can be assigned to both the positive and negative pole of each lead. Now there are six leads, with a positive and a negative pole, and each pole has an angle value. This six-lead system is used for determining the mean electrical axis of ventricular depolarization.

“a” = augmented, “V” = vector, “R” = right arm, “L” = left arm and “F” = frontal (represents the left leg).

In lead aVR, RA is the positive pole and the negative pole compares LA and LL. In lead aVL, LA is the positive pole and the negative pole compares RA and LL. In lead aVF, LL is the positive pole and the negative pole compares RA and LA. Now there are six leads, with a positive and a negative pole, and each pole has an angle value. This six-lead system is used for determining the mean electrical axis of ventricular depolarization (see Figure 27.5).

■ Interpretation of the ECG

Electrocardiograms should be read in a systematic manner. There are four important steps in the process of interpreting an ECG (Figure 27.7).^{5,96}

Determination of Heart Rate

All recording paper has a series of marks at the top or bottom of the paper. These marks are spaced so that they are three seconds apart at a 25 mm/s paper speed. To estimate heart rate per minute, the number of complexes that occur in three seconds are

counted and multiplied by 20. A second method of determining heart rate per minute is to count the number of small boxes from S-wave to S-wave and divide into 1500 (there are 1500 small boxes per minute at 25 mm/s paper speed).

Determination of Heart Rhythm

- Is the heart rate normal or abnormal for the species (bradycardia or tachycardia)?
- Is the heart rhythm regular or irregular?
- Is there a P-wave for every QRS-complex, and is there a QRS-complex for every P-wave?
- Are the P-waves related to the QRS-complexes?
- Do all the P-waves and all the QRS-complexes look alike?

Determination of Mean Electrical Axis

To determine the heart axis, the mean wave of electrical activity in the frontal plane that occurs when the ventricles depolarize is measured. The procedure for a rough estimation of the axis is simple and involves three steps (Figure 27.7):

- Find an isoelectric lead.
- Use the six-axis reference system chart and find which lead is perpendicular to the isoelectric lead (see Figure 27.5).
- Determine if the perpendicular lead is positive or negative on the tracing and examine the angle value on the six axis reference system. Compare these values with reference values (Table 27.1).

When all leads are isoelectric it is not possible to determine the heart axis and the heart is “electrically vertical” (Figure 27.8). The heart axis can be precisely determined by graphing leads II and III. Alternatively the heart axis can be calculated from the vectors of ventricular depolarization in leads II and III (in Figure 27.9 named **a** and **b** respectively) using Bailey’s hexaxial system (see Figure 27.2).⁶⁷ The angles β and τ are known (60° and 30° , respectively).

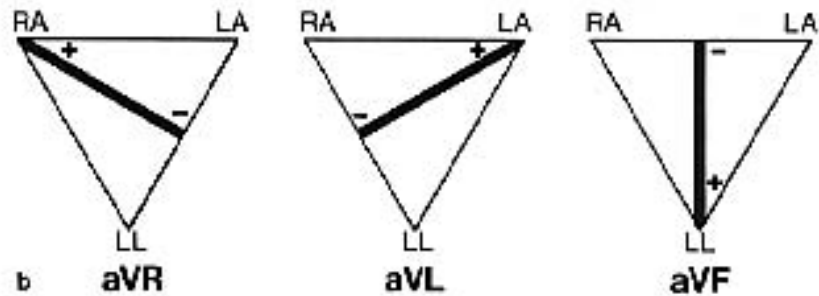
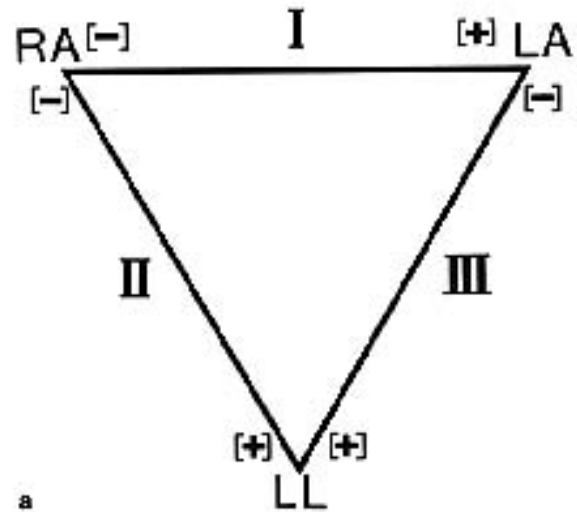

FIG 27.6 **a**) Einthoven’s triangle depicts the three bipolar limb leads I, II and III. The electrodes are attached to the right wing (RA), the left wing (LA) and the left limb (LL). The right hind limb (RL) of the bird is connected to the ground electrode. In lead I, RA is the negative pole and LA the positive pole. In lead II, RA is the negative pole and LL is the positive pole. In lead III, LA is the negative pole and LL is the positive pole. The three leads form in theory an equilateral triangle. **b**) The augmented unipolar leads (aVR, aVL and aVF) provide three more leads. In lead aVR, RA is the positive pole and the negative pole compares LA and LL. In lead aVL, LA is the positive pole and the negative pole compares RA and LL. In lead aVF, LL is the positive pole and the negative pole compares RA and LA (courtesy of J. T. Lumeij).

Then:

$$b = p \cos \beta$$

$$q = p - a = [b/\cos \beta] - a$$

$$\tan \tau = h/q$$

$$h = q \tan \tau = q \tan (90 - \beta) = q \cot \beta$$

$$\tan \alpha = h/a = [q/a] \cot \beta = \{([b/a] \cos \beta) - 1\} \cot \beta$$

Thus, α can be calculated from known parameters and the mean electrical axis can be determined. The calculations have been computerized by the primary author to facilitate the determination of the mean electric axis.⁶⁷

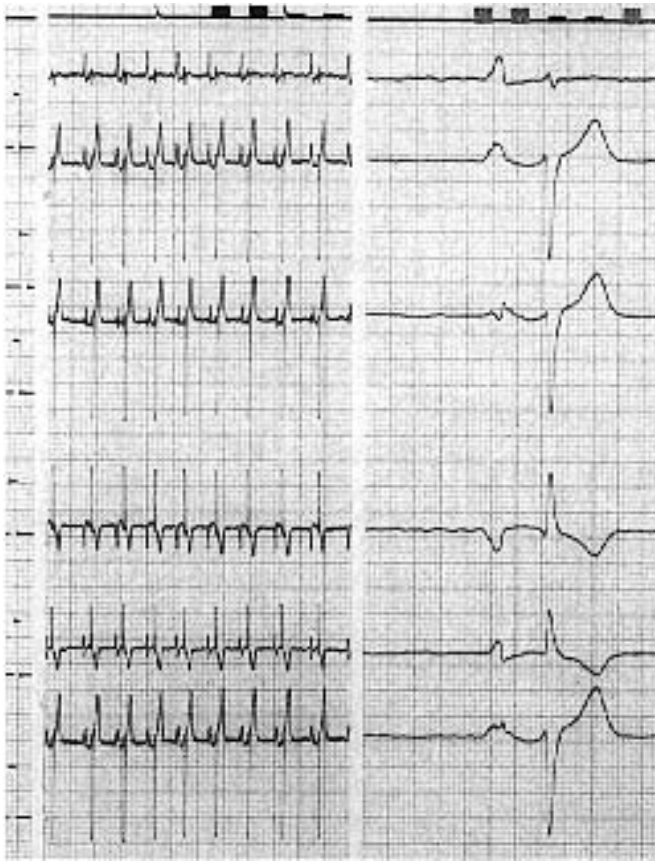

FIG 27.7 Normal pigeon electrocardiogram. From top to bottom: leads I, II, III, aVR, aVL, aVF. 1 cm = 1 mV. Paper speed 25 mm/s and 200 mm/s (courtesy of J. T. Lumeij).

Heart Rate: 250 (SS-interval is six boxes at 25 mm/s paper speed)

Rhythm: Sinus arrhythmia (the first two SS intervals are not equidistant)

Axis: -90° (The vector of ventricular depolarization is isoelectric in lead I. In the six-axis reference system (see Figure 27.5) lead aVF is perpendicular to lead I. The ventricular depolarization vector is negative in lead aVF. Angle value on the six-axis ref. chart is -90°)

Measuring: P-wave = 0.02 s, 0.4 mV. PR-interval = 0.06 s. QRS-complex = 0.015 s, 1.9 mV. ST-segment = 0.1 mV elevated, ST-slurring. T-wave discordant and positive in lead II, 0.8 mV. QT-interval = 0.07 s.

Electrocardiographic Diagnosis: Normal pigeon electrocardiogram.

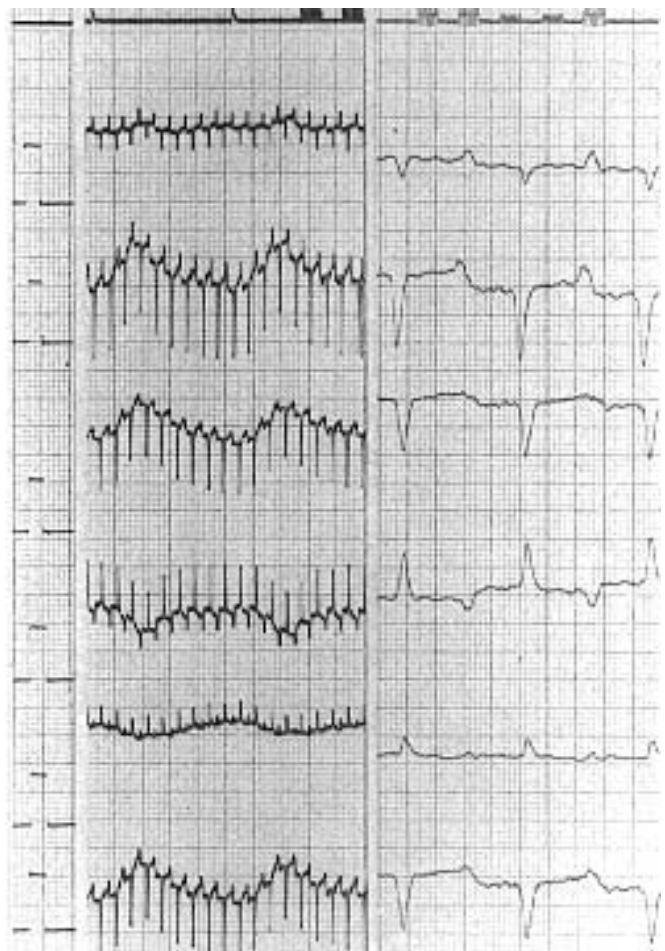

Representative ECG of an African Grey Parrot, with six simultaneously recorded leads. From top to bottom: leads I, II, III, aVR, aVL and aVF. Paper speed 25 mm/s and 200 mm/s, 1 cm = 1 mV (courtesy of J. T. Lumeij).

Heart Rate: 540

Rhythm: Normal sinus rhythm

Axis: -105° (leads I and aVL are closest to being isoelectrical. Leads aVF and II are perpendicular to these respective leads and negative. The heart axis is midway between -120° and -90°)

Measuring: P-wave = 0.015 s, 0.5 mV, slight 'P on T phenomenon'. PR-interval = 0.05 s. QRS-complex = 0.015 s, QS 1.3 mV. T-wave discordant 0.18 mV. QT-interval = 0.06 s

Electrocardiographic Diagnosis: Probably a normal electrocardiogram. The axis is borderline compared to reference values for the African Grey Parrot, but no other abnormalities can be identified.

In mammals, right axis deviation occurs when the vector of ventricular depolarization has moved clockwise on Bailey's six-axis reference system from a positive value (eg, $+40^\circ$ to $+100^\circ$ in dogs) toward the right side of the body. With left axis deviation, the vector moves counterclockwise toward the left side of the body. In mammals, right axis deviation is seen with enlargement of the right ventricle, while left axis deviation is seen with hypertrophy of the left ventricle.

Deviations in mean electric axis in birds are confusing because the normal heart axis is negative (except for some strains of chickens). More cases of left and right axis deviation in birds, and their associated clinical and pathologic changes, need to be determined before the importance of these electrocardiographic findings can be ascertained (Figures 27.10, 27.11, 27.12).

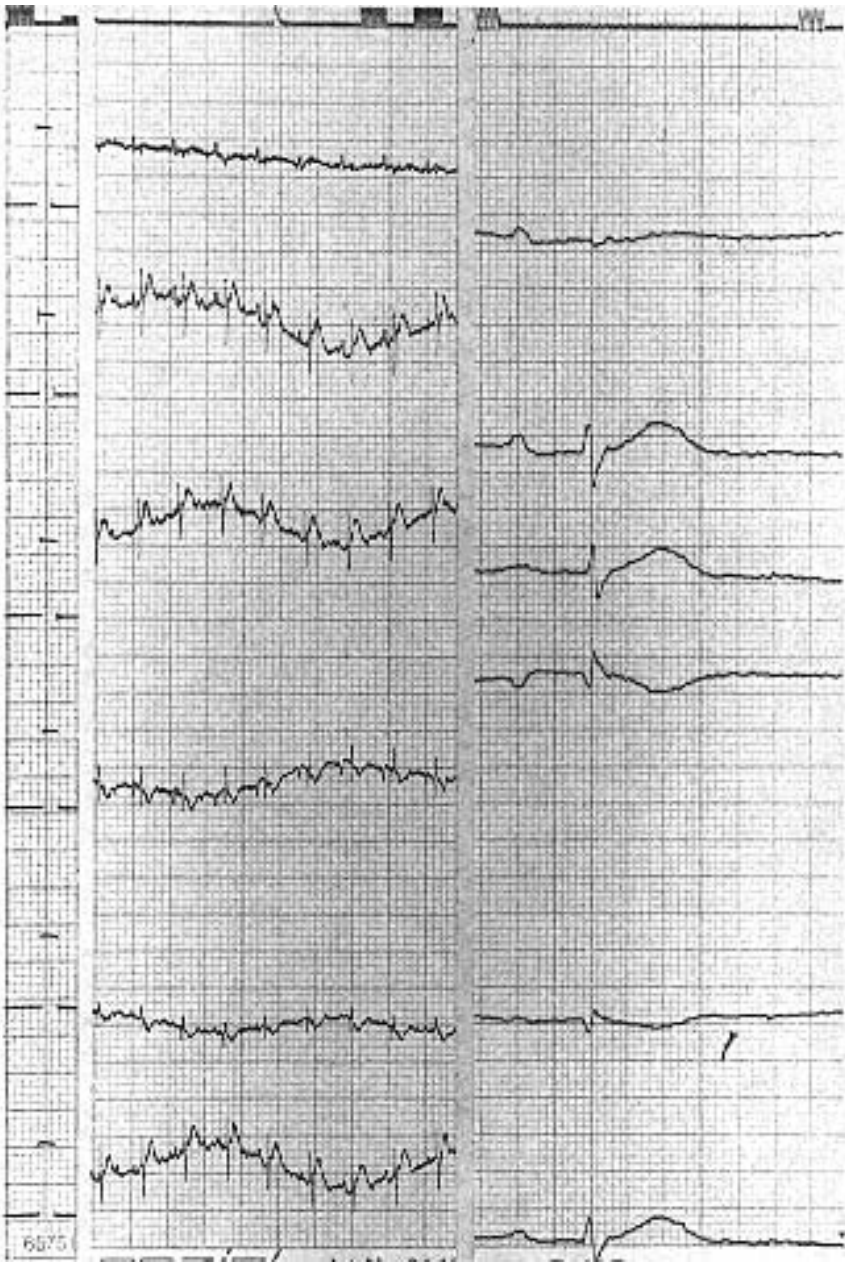

FIG 27.8 Electrically vertical heart in an African Grey Parrot. From top to bottom: leads I, II, III, aVR, aVL and aVF. 1 cm = 1 mV; paper speed 25 mm/s and 200 mm/s. This bird was presented with dyspnea and seizures. The heart axis is indeterminate because all leads are isoelectric. Radiographs indicated a dilated proventriculus. Myocarditis has been reported as a possible component of neuropathic gastric dilatation of psittacine birds (courtesy of J. T. Lumeij).⁹⁷

Measuring

All measurements are made on the lead II rhythm strip. Measurements include the amplitude and the duration of the different electrocardiographic complexes (see Figure 27.3). The values found should be compared with the reference values (Table 27.1).

- **P-Wave:** With right atrial hypertrophy the P-wave becomes tall and peaked (P pulmonale), and with left atrial hypertrophy the P-wave becomes too wide (P mitrale). There is an increased number of P waves with tachycardia. P pulmonale has been associated with dyspnea induced by aspergillosis or tracheal obstruction. A tall, wide P-wave is suggestive of biatrial enlargement and is common with influenza virus in gallinaceous birds.

- **PR-Interval:** In the normal pigeon ECG, a T_a -wave can be seen in the PR-segment, indicating repolarization of the atria. A small T_a may occur also in some asymptomatic parrots. This finding is considered normal and should not be interpreted as a sign of right atrial hypertrophy as it is in the dog.

- **QRS-Complex:** Two measurements are made on the QRS-complex. The duration is measured from the beginning of the R-wave to the end of the S-wave. The second measurement is the amplitude of the S-wave, measured from the baseline downwards. Low voltage ECGs occur often in birds with pericardial effusion (Figure 27.13). A QRS-complex that is too wide or too tall indicates left ventricular hypertrophy (Figure 27.14). Prominent R-waves are suggestive for right ventricular hypertrophy^{17,41,59} and it might be that a R_1 - R_2 - R_3 pattern is comparable to an S_1 - S_2 - S_3 pattern in dogs (see Figure 27.12)

- **ST-Segment:** The ST-segment in the avian electrocardiogram is often short or absent. When present, it may be elevated above the baseline, which should *not* be interpreted as a sign of left ventricular hypertrophy,

myocardial hypoxia, myocarditis or hypocalcemia as it is in the dog.^{5,24,56,67,96}

- **T-Wave:** In the normal avian ECG, the T-wave is always in the opposite direction to the main vector of the ventricular depolarization complex, and always positive in lead II. When the T-wave changes its

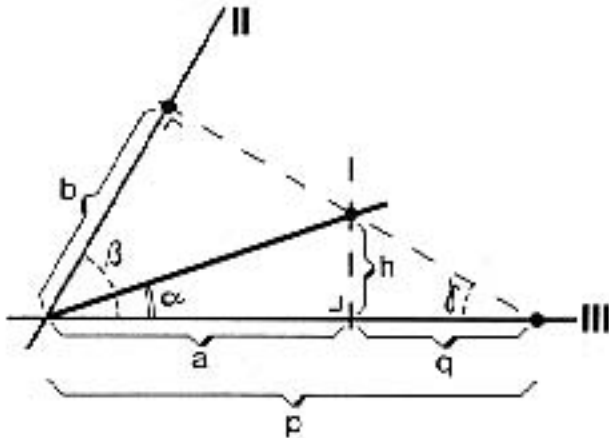

FIG 27.9 Mathematical derivation of the mean electrical axis of ventricular depolarization in the frontal plane. Known parameters are the vectors in lead II and III (named b and a, respectively, and the angles β and τ (60° and 30° , respectively), α can be derived using the formulae described in the text (courtesy of J. T. Lumeij. Reprinted with permission⁶⁷).

polarity, it suggests that myocardial hypoxia is occurring (Figure 27.15). The same is true for a T-wave that progressively increases in size (eg, during anesthesia). T-wave changes may also occur in association with electrolyte changes (eg, increased T-wave amplitude with hyperkalemia).³

▪ **QT-Interval:** Prolongation of the QT-interval might be associated with electrolyte disturbances like hypokalemia and hypocalcemia. In African Grey and Amazon parrots, the QT-interval was significantly ($P < 0.05$) prolonged during isoflurane anesthesia (see Table 27.1). The effects of various diseases and compounds on the heart are listed in Table 27.2.



Arrhythmias

Sinus Arrhythmias

The normal rhythm of the heart is established by the SA node. A normal sinus rhythm does not vary in rate from beat to beat. An increase in vagal activity may decrease the heart rate, while a decrease in vagal activity may increase the heart rate. Heart rate may increase during inspiration and decrease during expiration and hence the S-S interval may not be equidistant. The associated rhythm is called sinus arrhythmia.

Sinus arrest is an exaggerated form of sinus arrhythmia and can be diagnosed if the pause is greater than

TABLE 27.2 Cardiovascular Effects of Selected Conditions or Agents^{6,17,18,28,30,32,39-41,43,46,53,54,60, 61,64,83-93}

Condition/Agent	Rhythm	SA node	AV node	ECG Changes
Dilated cardiomyopathy	Atrial arrhythmia Ventricular arrhythmia			Increased R-wave Negative T-wave Mean axis 0° to -170°
E. coli septicemia (Galliformes)				Elevated P-waves Elevated T-waves Elevated S-waves Elevated R-waves
Halothane	Decreased heart rate		First degree AV block	Increased PR-interval
Hyperkalemia (ducks)				Elevated T-waves
Hypokalemia	Sinus arrhythmia Sinus bradycardia VPCs	SA block	Incomplete AV block AV junctional PC	
Influenza virus (Galliformes)	Ventricular tachycardia VPCs		Decreased conduction	Increased ST-segment Increased TP-interval Increased PR-interval Increased RS-interval
Newcastle disease virus (Galliformes)	Ventricular arrhythmias		Decreased conduction	Fusion T- and P-waves Increased T-waves
Thiamine deficiency	Sinus arrhythmia Sinus bradycardia Sinus arrest VPCs			Decreased ST-segment
Vitamin E deficiency	Sinus arrhythmia Sinus bradycardia Sinus arrest VPCs		Sinus bradycardia	Decreased PR-interval Elevated ST-segment

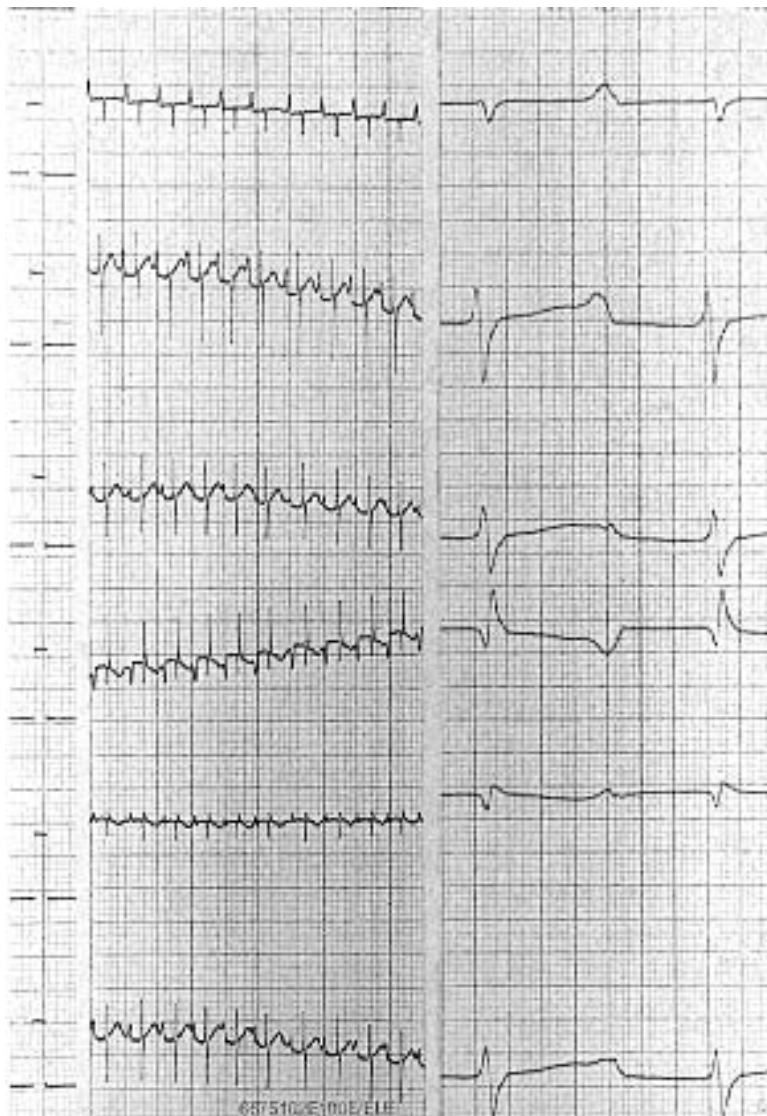

FIG 27.10 History: ECG of a 37-year-old African Grey Parrot with congestive heart failure. From top to bottom: leads I, II, III, aVR, aVL and aVF. 1 cm = 1 mV; paper speed 25 mm/s and 200 mm/s.

Heart Rate: 320

Rhythm: Sinus arrhythmia

Axis: -150° (The vector of ventricular depolarization is isoelectric in lead III. In the six-axis reference system [Figure 27.5], lead aVR is perpendicular to lead III. The ventricular depolarization vector is positive in lead aVR. The angle value on the six-axis reference chart is -150°)

Measuring: P = 0.4 mV, 0.025 s. PR-interval = 0.09 s. QRS-complex = 0.02 s, R = 0.6 mV, QS = 0.9 mV, T = 0.2 mV and QT = 0.11 s.

Electrocardiographic Diagnosis: Widening of P-wave (P-mitrale), widening of the QRS-complex and axis deviation are all indicative of left atrial and ventricular enlargement. An increase in the amplitude of the R-wave has been associated with right ventricular failure in chickens.

Clinical Findings: This bird was presented with severe dyspnea and inability to perch. Radiographs revealed cardiohepatomegaly and ascites. Ultrasonography confirmed the presence of ascites, but no free pericardial fluid could be seen. A liver biopsy was performed because of elevated bile acids (220 $\mu\text{mol/l}$). Histologic examination revealed fibrotic changes, possibly secondary to chronic liver congestion (right-sided heart failure). Treatment of the congestive left and right heart failure with furosemide 1 mg/kg BID and digoxin 0.045 mg/kg SID resolved the clinical signs within ten days (courtesy of J. T. Lumeij).

twice the normal S-S interval. A sinoatrial block occurs when an electrical impulse from the sinoatrial node fails to activate the atria. The pauses are exactly twice the S-S interval. A continuous shifting of the pacemaker site in the SA node or the atrium, and hence a continuously changing configuration of the P-wave, is called wandering pacemaker. Sinus arrhythmia, sinus arrest, sinoatrial block and wandering pacemaker have been reported in association with normal respiratory cycles and are considered physiologic in birds.^{4a,39,67,99}

Sinus bradycardia can be induced by vagal stimulation and can be converted by the administration of atropine. Various anesthetics (eg, halothane, methoxyflurane, xylazine and acepromazine) have been reported to cause sinus bradycardia, when atropine is not given simultaneously. Hypothermia, which may accompany long-term anesthesia, may potentiate this arrhythmia.^{1,37,58,63}

Pathologic conditions that may induce sinus bradycardia and sinus arrest include hypokalemia,^{85,90} hyperkalemia,³ thiamine deficiency,¹¹ and vitamin E deficiency.⁸⁸ The conduction abnormalities (SA block, AV block) caused by potassium deficiencies can be corrected by administering atropine, suggesting that potassium increases vagal tone to the SA and AV nodes.⁸⁷

Several toxins have been reported to induce bradycardia, including, organophosphorus compounds and polychlorinated biphenyls.⁴³ Reflex vagal bradycardia may occur when pressure is exerted on the vagus nerve by neoplasms, and space occupying lesions impinging on the vagal nerve should be considered when unexplained atropine responsive bradycardia is seen. One case of sinoatrial arrest in an African Grey Parrot, which was associated with syncopal attacks, was seen at the primary author's clinic. The underlying disorder could not be determined (Figure 27.16).

If the sinoatrial node is sufficiently depressed by vagal stimulation, another part of the conducting system may take over the pacemaker function and escape beats may occur. When an electrical impulse originates

below the SA node in the atria the configuration of the P-wave will be abnormal, but positive in lead II. When an electrical impulse originates in fibers near the AV node (junctional beat), the P-wave may be absent or negative in lead II, indicating retrograde conduction (Figure 27.11). With ventricular beats the ectopic focus is localized in the fibers of the ventricle. The QRS complex is usually abnormal (but may be normal) and is unrelated to the P-wave. Atrioventricular nodal escape rhythm has been reported in ducks with sinus bradycardia induced by hyperkalemia.³

Atrial Arrhythmias

Atrial tachycardias may be seen as a result of pathologic conditions of the atrium. Sinus tachycardia (two times normal) has been reported in chickens infected with avian influenza virus.⁶⁴ When the heart rate is rapid, the P-wave may be superimposed on the T-wave (P on T phenomenon). This phenomenon has been recorded in 16% of normal Amazon parrots and in six percent of African Grey Parrots.⁶⁷

When (paroxysmal) supraventricular tachycardia is associated with valvular insufficiency, digoxin therapy is indicated. It is imperative to differentiate between junctional tachycardia (presence of negative P-waves due to retrograde impulse conduction) and ventricular tachycardia/atrioventricular dissociation (presence of normal P-waves that are usually not followed by a QRS complex; no retrograde impulse conduction to the atrium), because administration of digoxin may potentiate ventricular fibrillation in birds with ventricular arrhythmias.

Atrial fibrillation occurs when electrical impulses are generated in the atrium in a rapid and irregular way, and the atrium is in a state of permanent diastole. Impulses reach the AV node in a high frequency and at irregular intervals, and hence the ventricular rhythm is irregular. The ECG is characterized by the absence of normal P-waves, normal QRS complexes (which may have an increased amplitude and duration because of ventricular hypertrophy) and irregular S-S intervals. Instead of the normal P-waves,

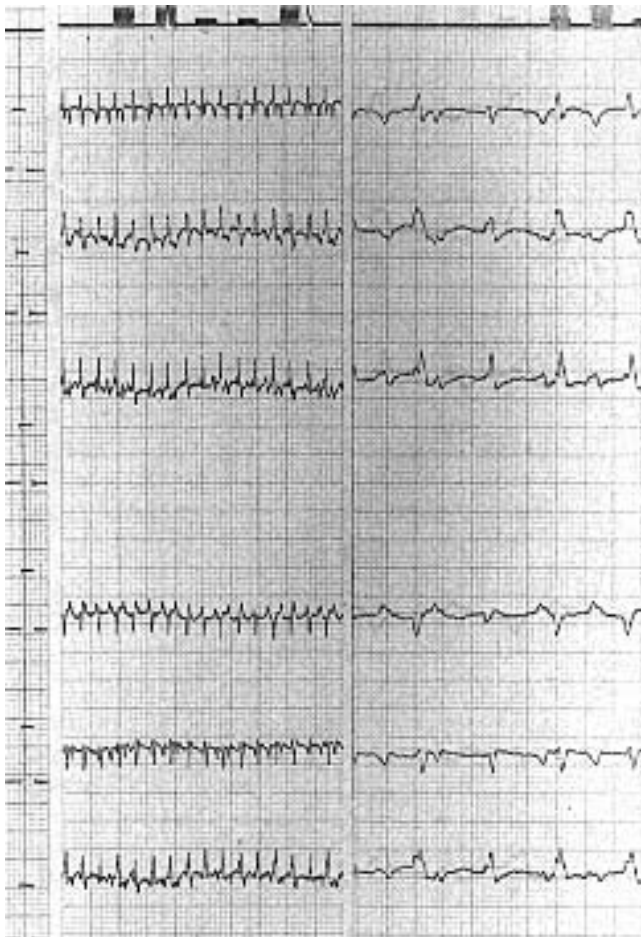

FIG 27.11 *History:* ECG of a 13-year-old African Grey Parrot with congestive heart failure and atherosclerosis. From top to bottom: leads I, II, III, aVR, aVL and aVF. 1 cm = 1 mV; paper speed 25 mm/s and 100 mm/s.

Heart Rate: Atrial rate 640, ventricular rate 480.

Rhythm: Complete AV-block with ventricular escape rhythm. (5 P-waves can be seen in lead I of the 100 mm/s ECG strip as negative deflections evenly spaced at 0.09 s. In this strip there are 4 ventricular complexes spaced at 0.12 s)

Axis: +80° (see below).

Measuring: P-wave negative in lead I and II. Bizarre ventricular complexes.

Electrocardiographic Diagnosis: Severe loss of function of the cardiac conduction system. Negative P-wave in lead I and II is indicative of retrograde conduction from ectopic focus in the atrium or AV-node. An idioventricular rhythm that is less than the atrial rhythm is characteristic for complete AV-block. Although there is dissociation between atrial and ventricular rhythm, the condition is not called atrioventricular dissociation because the ventricular rate is slower than the atrial rate. AV-dissociation is a form of ventricular tachycardia with a ventricular rate higher than the atrial rate. Bizarre ventricular complexes which are wide and positive in lead II are indicative of a focus in the ventricular wall, which acts as the pacemaker for the escape rhythm. The heart axis of +80° is therefore not indicative of ventricular hypertrophy.

Clinical Findings: This bird was presented with a two day history of dyspnea and anorexia. Radiographs indicated a marked haziness of the peritoneal cavity and a poorly defined cardiohepatic silhouette. The bird died on the second day of hospitalization. Post mortem examination revealed severe cardiomegaly, ascites and atherosclerosis of large arteries. Pulmonary edema was present also (courtesy of J. T. Lumeij).

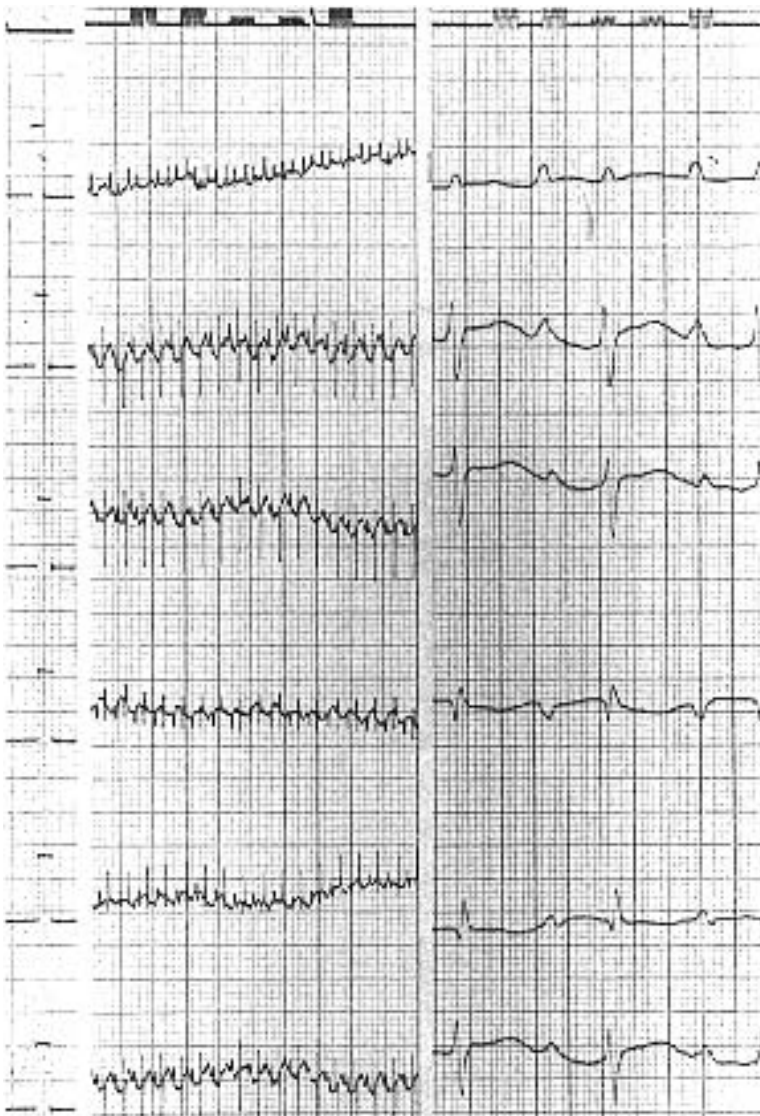

FIG 27.12 History: ECG of three-year-old African Grey Parrot with pericardial effusion and ascites. From top to bottom: leads I, II, III, aVR, aVL and aVF. 1 cm = 1 mV; paper speed 25 mm/s and 200 mm/s.

Heart Rate: 480

Rhythm: Normal sinus rhythm

Axis: -30° to -60°

Measurements: P-wave = 0.015 s, 0.6 mV. QRS-complex = 0.015 s, R = 0.6 mV, QS = 0.6 mV. T-wave = 0.3 mV. QT-interval = 0.065 s

Electrocardiographic Diagnosis: P pulmonale and prominent R-waves in leads I, II and III. Heart axis shift to $-45^{\circ} \pm 15^{\circ}$. These changes are consistent with right ventricular failure.

Clinical Finding: This bird was presented with dyspnea. Radiographs indicated an enlarged cardiac silhouette and ascites. Abnormal clinicopathologic findings included hypoproteinemia (25 g/l) and hypoalbuminemia (6 g/l). Postmortem findings included pale and enlarged kidneys (might explain proteinuria and hypoproteinemia). The pericardial sac contained a large amount of clear yellow fluid, which was also present in the peritoneal cavities. The endocardium, myocardium and epicardium were grossly normal. Renal failure, with secondary hypoalbuminemia, ascites and pericardial effusion, was considered to be the primary disease in this case. Right ventricular failure will develop before left ventricular failure because the weaker right ventricle is less able to compensate for the additional strain induced by pericardial effusion. Both P pulmonale and increased R-waves in lead II have been associated with right ventricular failure in birds (courtesy of J. T. Lumeij).

baseline undulations (F-waves) may be seen on the ECG.^{4,24}

Atrial flutter is characterized by the regular occurrence of symmetrical P-waves, which appear to be saw-toothed. Usually the ventricles respond with some degree of atrioventricular block. The condition has never been reported in birds but artifacts from shivering, thermal polypnea, buccopharyngeal flutter and 60 cycle interference can be confused with atrial flutter. Atrial premature contractions, atrial fibrillation and atrial flutter are usually associated with serious atrial dilatation due to valvular insufficiency. Atrial fibrillation associated with left atrial enlargement due to mitral valve insufficiency has been reported in a Pukeko with congestive heart failure.⁴ Digoxin is considered the treatment of choice for atrial fibrillation, but the prognosis should be guarded because of the presence of marked cardiac pathology.^{4,24}

Ventricular Arrhythmias

Supraventricular tachycardias may originate from the sinoatrial node (sinus tachycardia), atrium (atrial tachycardia) or junctional area (junctional tachycardia). Differentiation between sinus tachycardia and atrial tachycardia may be accomplished by measuring the P-P interval. This interval is perfectly equidistant in atrial tachycardia but may be irregular in sinus tachycardia due to vagal effects. Junctional tachycardias can be diagnosed by the presence of inverted P-waves in lead II. The most common cause of sinus tachycardia is nervousness. But it is likely that stress, pain and other known causes of sinus tachycardia in dogs (eg, electrocution) may also precipitate the condition in birds.

Ventricular premature contractions (VPCs) are characterized by QRS complexes that are unrelated to the P-waves. Two, three or four and more premature contractions of the atria, junctional area or ventricle in a row, are called a pair, run and tachycardia respectively. Bigeminy is a rhythm characterized by alternating normal beats and premature contractions, while in trigeminy two normal beats are followed by one premature contraction.

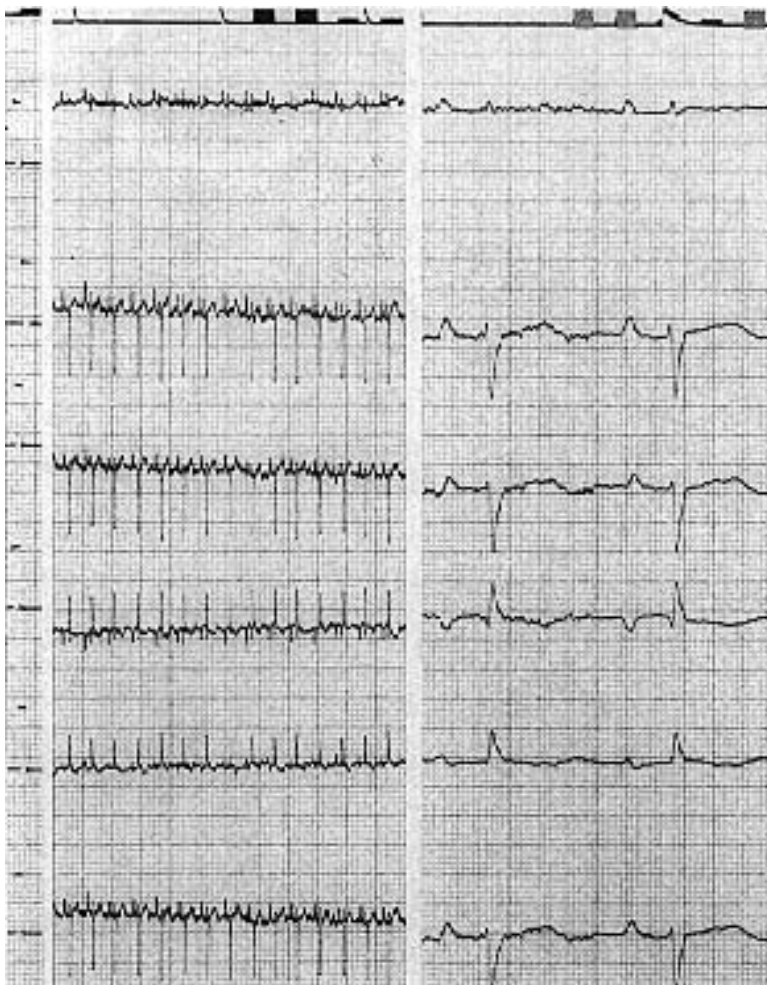

FIG 27.13 Low voltage ECG caused by pericardial effusion in a pigeon. From top to bottom: leads I, II, III, aVR, aVL and aVF. 1 cm = 1 mV; paper speed 25 mm/s and 200 mm/s.

Heart Rate: 375 (SS-interval four boxes at 25 mm/s paper speed).

Rhythm: Sinus tachycardia.

Axis: -90° (see Figure 27.7).

Measuring: P-wave = 0.015 s, 0.3 mV. PR-interval = 0.04 s. QRS-complex = 1 mV, 0.015 s. ST-segment normal. T-wave discordant, positive in lead II, 0.2 mV. QT-interval = 0.075 s.

Electrocardiographic Diagnosis: Sinus tachycardia, shortening of the PR-interval and low voltage QRS-complexes. Possibly pericardial effusion. The PR-interval varies inversely with heart rate, and in general is shorter when the heart rate is rapid. Pericardial effusion is the cardiovascular disease entity most often associated with low voltage complexes. Serofibrinous pericarditis was diagnosed in this bird at necropsy (courtesy of J. T. Lumeij).

Ventricular premature contractions in birds have been associated with hypokalemia,^{85,90} thiamine deficiency,¹¹ vitamin E deficiency,⁸⁸ Newcastle disease and avian influenza viruses,^{60,64} myocardial infarction due to lead poisoning⁶⁰ and digoxin toxicity.⁶³ The rhythm may be regular or irregular in birds with ventricular tachycardia. Positive P-waves can be identified in lead II at a lower frequency. Ventricular capture beats (normal P-QRS complexes in between

abnormal PVCs) and ventricular fusion beats (a QRS-complex intermediate between a normal P-QRS complex and a bizarre QRS-complex that is formed by the simultaneous discharge of the ectopic ventricular focus and the normal AV node) are characteristic of ventricular tachycardia.

A special form of ventricular tachycardia is atrioventricular dissociation. In this condition, the atrial and ventricular rhythms are independent of each other, whereby the atrial rate is lower than the junctional or idioventricular rate. Runs of multiple VPCs, ventricular tachycardia or a bigeminal rhythm have been reported in birds with Newcastle disease or avian influenza virus infections.⁶⁴

VPCs, ventricular tachycardia and ventricular fibrillation may occur during periods of hypoxia and with the use of halothane (Figure 27.17). Changes in the configuration of the T-wave should alert the clinician that myocardial hypoxia is present and more severe ECG abnormalities are imminent.

Atrioventricular Node Arrhythmias

Conduction disturbances in the atrioventricular node may lead to various gradations of atrioventricular (AV) heart block. When the impulse through only the AV node is delayed, first degree AV block is present. In second degree AV block some impulses do not reach the ventricles, but the majority of P-waves are followed by a QRS-complex. Third degree AV block or complete heart block is characterized by independent activity of atria and ventricles, whereby the frequency of the atrial depolarizations is higher than the ventricular depolarizations.

First-Degree Heart Block

First-degree heart block has been reported as the result of the administration of various anesthetics such as halothane⁶³ and xylazine,⁵⁸ whereby the PR-interval may increase to three to four times its normal value. The condition is associated with severe bradycardia. Atropine may be used to prevent or reverse the condition.⁵⁸

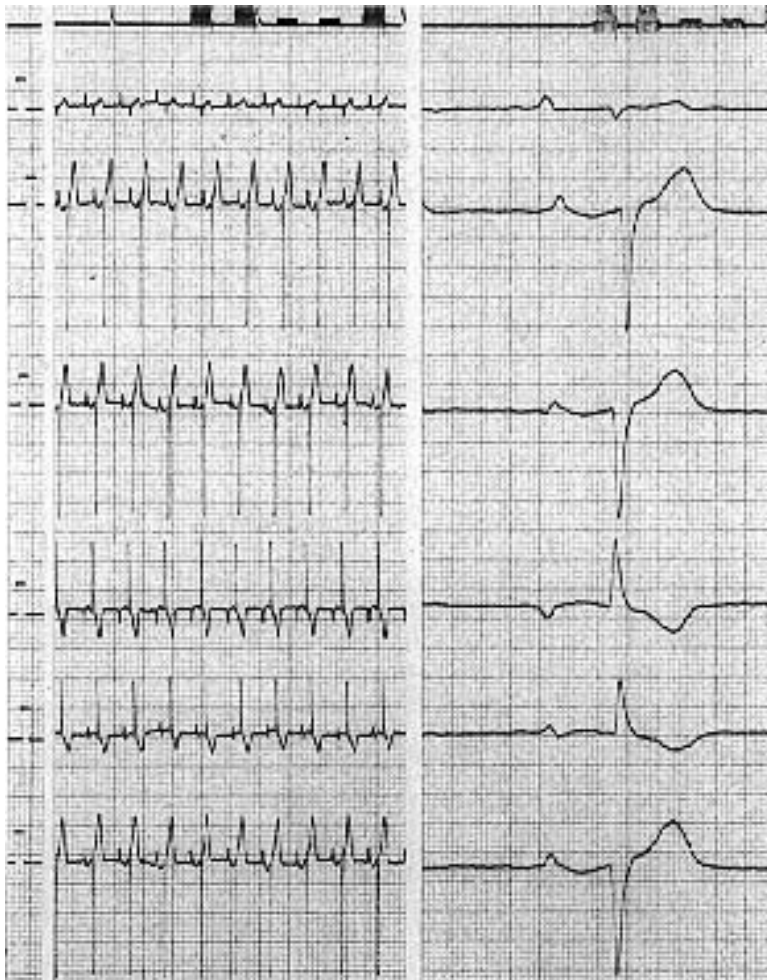

FIG 27.14 Ventricular hypertrophy in a pigeon. From top to bottom: leads I, II, III, aVR, aVL and aVF. 0.5 cm = 1 mV; paper speed 25 mm/s and 200 mm/s. Heart Rate: 250.

Rhythm: Normal sinus rhythm.

Axis: -100° .

Measuring: P-wave = 0.5 mV (0.25 cm at 0.5 cm = 1 mV), 0.015 s. PR-interval = 0.06 s. QRS-complex = 0.02 s (4 boxes at 200 mm/s), 4.2 mV (2.1 cm at 0.5 cm = 1 mV). ST-segment = 0.2 mV elevated. T-wave = 1.4 mV. QT-interval = 0.08 s.

Electrocardiographic Diagnosis: QRS complexes are too wide and too tall, which is suggestive of ventricular hypertrophy. Nonselective angiocardiography was performed in this pigeon. Rapid sequence serial radiographs showed impaired ventricular function (courtesy of J. T. Lumeij).

Second-Degree Heart Block

Second-degree atrioventricular block Mobitz type 1 (Wenckebach phenomenon) has been reported as a physiologic phenomenon in five percent of trained racing pigeons⁵⁶ (Figure 27.18) and is seen occasionally in asymptomatic parrots⁶⁷ and raptors.^{4a} In this form of AV block the PR-interval lengthens progressively until a ventricular beat is dropped. In a study with racing pigeons, second-degree AV block was observed in 24% of subclinical birds. It should be noted, however, that in the latter study the birds were

restrained in a mechanical device during recording of the ECG. The birds had been in the device for one to two hours before ECGs were made and some of them were nearly asleep.⁹⁹

Second-degree AV blocks that can be corrected with atropine have been described in several avian species. This stimulatory effect of atropine on the avian heart suggests that this agent functions, as it does in mammals, to decrease parasympathetic tone to the SA and AV nodes.⁶³ Complete AV dissociation has been documented in a parakeet.¹⁰¹

Third-Degree Heart Block

Third-degree AV block is characterized by a slow ventricular (escape) rhythm. The ventricular complexes may have a normal configuration or may be idioventricular depending on the site of ventricular impulse formation. The condition should be differentiated from atrioventricular dissociation and ventricular tachycardia whereby there is also no relation between P-waves and QRS-complexes, but wherein the ventricular rate is higher than the atrial rate.

Complete AV block with an idioventricular rhythm (auricular rate 300 and ventricular rate 200) has been seen in chickens with hypokalemia.⁸⁵ Complete AV block with an atrial rate of 640 and a ventricular rate of 480 was diagnosed at the primary author's clinic in an African Grey Parrot with severe cardiomegaly, ascites and atherosclerosis (see Figure 27.11).

Intraventricular Conduction Disturbances

Intraventricular conduction disturbances such as left bundle branch block and right bundle branch block and the Wolf-Parkinson-White (WPW) syndrome have not been reported in birds. In the latter condition, an accessory pathway bypasses the AV node and conducts atrial impulses directly to the ventricles, which result in a shortened PR-interval and bizarre QRS-complexes.

There are no reports on the clinical use of antiarrhythmic agents in avian medicine, and appropriate veterinary or human textbooks should be consulted for further information.

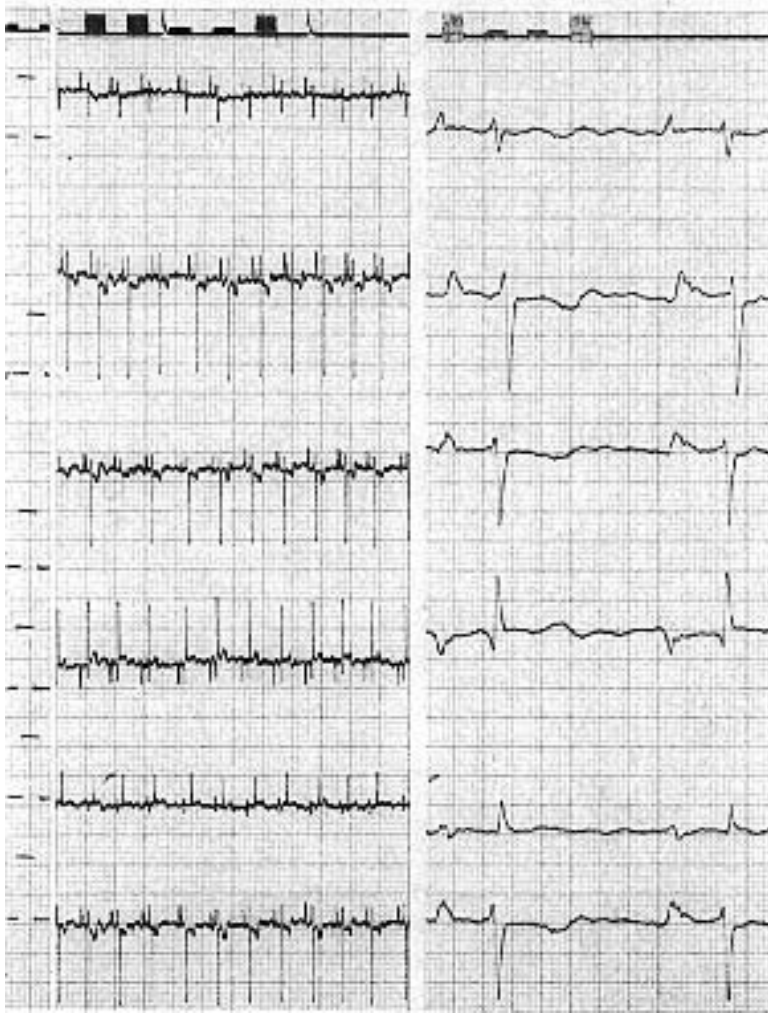

FIG 27.15 Electrocardiographic effects of myocardial hypoxia in a pigeon. From top to bottom: leads I, II, III, aVR, aVL and aVF. 1 cm = 1 mV; paper speed 25 mm/s and 200 mm/s.

Heart Rate: 300 (SS-interval is 5 boxes at 25 mm/s paper speed).

Rhythm: Sinus arrhythmia.

Axis: -94° (see Figure 27.7).

Measuring: P-wave = 0.015 s, 0.4 mV. PR-interval = 0.05 s. QRS-complex = 0.015 s, 1.7 mV. ST-segment = 0.1 mV depressed. T-wave concordant and negative in lead II, 0.2 mV. QT-interval = 0.07 s.

Electrocardiographic Diagnosis: Myocardial hypoxia. In this patient hypoxia was caused by a local mycotic tracheitis causing an inspiratory stridor and severe dyspnea. ST-depression and reversal of the T-wave during anesthesia are suggestive of myocardial hypoxia (courtesy of J. T. Lumeij).

Effects of Anesthesia

General anesthesia is typically associated with a time-related and progressive decrease in heart rate and a corresponding decrease in blood pressure. Methoxyflurane and halothane are both cardiac depressants that sensitize the heart to catecholamines. Halothane, methoxyflurane and ketamine have been reported to cause a decrease in heart rate in some

birds and an increase in heart rate in others.^{1,37} Xylazine, acepromazine and hypothermia have all been associated with bradycardia. Atropine can be used to increase the heart rate.

With halothane and methoxyflurane, respiratory and cardiac arrest routinely occur at the same time, and recovery from an anesthetic-induced cardiac arrest is rare. With isoflurane, respiratory arrest typically occurs several minutes before cardiac arrest. Birds with severe arrhythmias induced by an overdose of isoflurane may recover with appropriate intermittent partial pressure ventilation.

The increased PR-interval, first-degree AV block, decreased heart rate and conduction disturbances that occur with halothane anesthesia can be potentiated by the hypothermia that accompanies long-term anesthesia.¹ With severe hypothermia, the heart rate may decrease to less than 100 bpm with the PR-interval increasing to three to four times its normal value.⁶³

Cardiovascular Diseases

Congestive Heart Failure

Pathogenesis

Congestive heart failure is a clinical syndrome that can be defined as the compensated condition associated with fluid retention that results from a sustained inadequacy of the cardiac output to meet the demands of the body. The causes of congestive heart failure are numerous and include endocardial, epicardial, myocardial and combined diseases. The condition should be differentiated from other causes of fluid retention (see Chapter 19). A diagnosis may be especially difficult in constrictive pericarditis because the heart is not enlarged radiographically (*pericarditis fibrinosa in organisatione* that may lead to *pericarditis adhaesiva*).

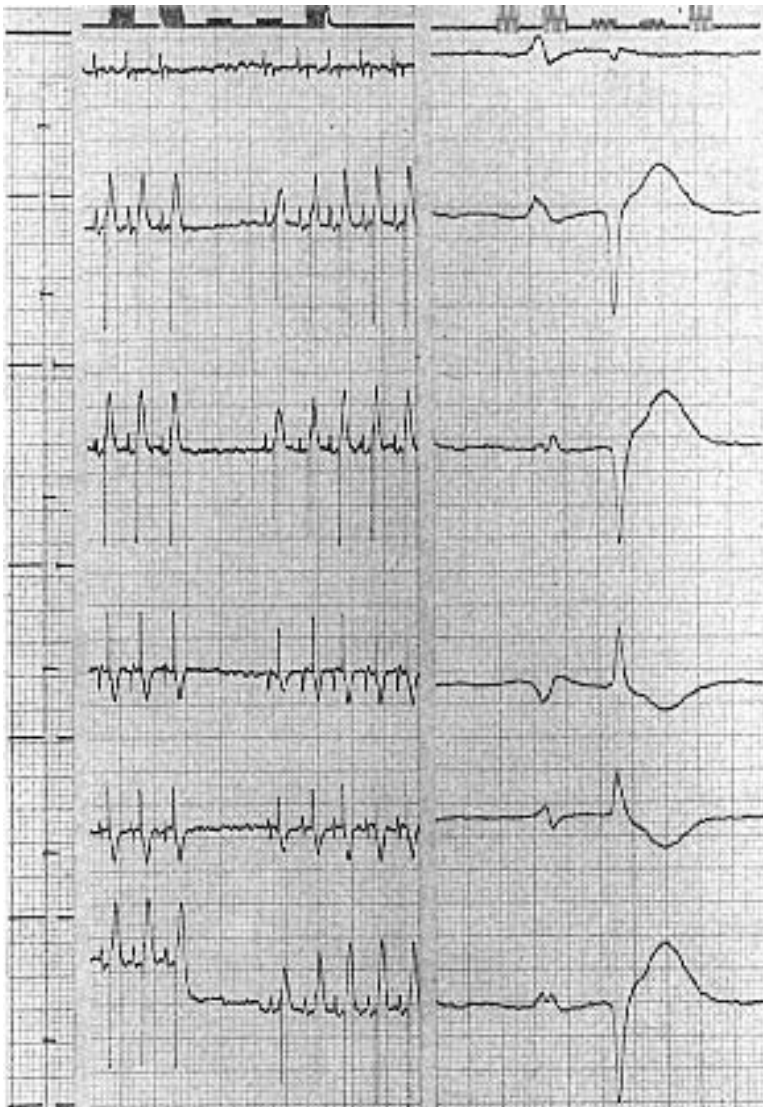

FIG 27.16 History: ECG of a 22-year-old African Grey Parrot with syncopal attacks. From top to bottom: leads I, II, III, aVR, aVL and aVF. 1 cm = 1 mV; paper speed 25 mm/s and 200 mm/s.

Heart Rate: 240.

Rhythm: Sinoatrial arrest.

Axis: -90° .

Measuring: P-wave = 0.02 s, 0.35 mV. PR-interval = 0.06 s. QRS-complex = 0.013 s. QS = 1.5 mV. T = 0.9 mV. QT-interval = 0.07 s.

Electrocardiographic Diagnosis: Sinus bradycardia and sinoatrial arrest. P mitrale indicative of left atrial enlargement. Repolarization changes in the ventricle are depicted by increased amplitude of the T-wave and prolongation of the QT-interval. Sinoatrial arrest and elevated T-waves are suggestive of hyperkalemia. Causes for sinoatrial arrest in birds include excessive vagal stimulation, thiamine deficiency, vitamin E deficiency and poisoning with organophosphorus compounds. The combination of P mitrale and sinoatrial arrest suggest a pathologic condition of the atrium such as atrial fibrosis or dilatation.

Clinical Findings: This bird was presented with short periods (several seconds) of syncope for several hours, two to three times a month. The bird was normal between attacks. Radiographs were unremarkable. Clinicopathologic abnormalities included leukocytosis with a left shift, hyperglobulinemia, and increased activity of AST. Potassium and calcium levels were normal. The sinoatrial arrest was considered to be a possible explanation for the observed syncopal attacks. The tentative diagnosis was bacterial/chlamydial myocarditis (courtesy of J. T. Lumeij).

The pathophysiology of congestive heart failure involves both backward failure and forward failure. Backward failure involves increased atrial and venous pressure due to a failing ventricle, while forward failure involves decreased renal blood flow resulting in sodium and fluid retention. In response to low blood volume, renin is released from the juxtaglomerular cells of the kidney. Renin acts on circulating angiotensinogen to form angiotensin I, which is converted to angiotensin II. Angiotensin II stimulates aldosterone synthesis. Aldosterone causes sodium and fluid retention.⁹⁴ Both mechanisms ultimately result in increased venous and capillary pressure, so that more fluid escapes by transudation in the interstitial spaces. The process is cumulative, ultimately leading to death from the local effects of fluid accumulation. (Compensated) congestive heart failure should be differentiated from (uncompensated) cardiogenic shock, which is characterized by acute cardiac dysfunction resulting in reduced arterial pressure and reduced tissue perfusion, without fluid accumulation in tissues.

Pulmonary edema predominates in isolated left ventricular disease. Systemic edema with hepatomegaly and ascites will predominate in isolated right ventricular disease, or when both ventricles are affected.

Left ventricular disease will result in increased pulmonary venous and capillary pressure. The active pulmonary constriction that occurs is known to cause an increase in pulmonary artery pressure and right ventricular failure in man. Atrial fibrillation, which is seen in left ventricular disease, presumably as a result of fibrotic changes disturbing the process of activation in the left atrium, is another contributing factor to the development of right heart failure. Closure of the left atrioventricular valves in man is dependent on the presence of atrial systole, perhaps through the effect of atrial relaxation. The resulting valvular insufficiency leads to pulmonary hypertension.

In birds, the right AV valve (muscular flap) thickens along with the right ventricle in response to an increased workload, and it has been postulated that this predisposes birds

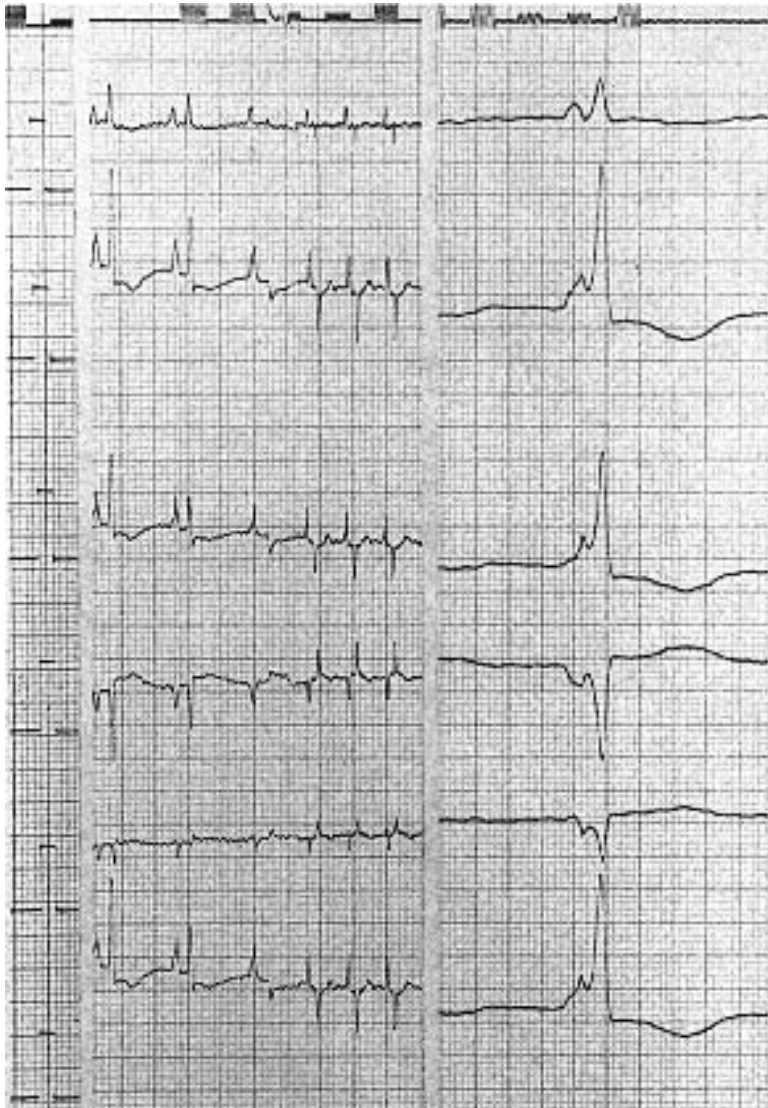

FIG 27.17 ECG of a Blue and Gold Macaw recovering from halothane anesthesia. From top to bottom: leads I, II, III, aVR, aVL and aVF. 1 cm = 1 mV; paper speed 25 mm/s and 200 mm/s. The 25 mm/s strip shows two idioventricular beats followed by a ventricular fusion beat and three normal P-QRS-T complexes. The 200 mm/s strip shows a bizarre QRS-complex caused by a discharge from an ectopic ventricular focus with a negative repolarization (T) wave. Halothane sensitizes the heart to adrenalin-induced arrhythmias (courtesy of J. T. Lumeij).

to right AV valvular insufficiency and right-sided heart failure.⁴⁸

Clinical Findings

Heart enlargement with a thin left ventricular wall has been reported as a common occurrence in mynah birds.²² In one study, 12 of 12 mynah birds had an abnormally thin left ventricle and ascites. The predominant clinical sign in affected birds was dyspnea (see Table 27.3). The heart lesions were associated

with liver fibrosis and end-stage iron storage disease.²⁰

In another report, an 11-year-old mynah was presented with dyspnea, polyuria and depression. Radiographs indicated cardiohepatomegaly and ascites. Echocardiography indicated biatrial enlargement, distended hepatic vessels and ascites. Color-flow doppler indicated a mitral regurgitation and right sided heart failure. The animal responded to treatment with furosemide (2.2 mg/kg) and digoxin (0.02 mg/kg). Repeated echocardiography indicated a decrease in the size of the heart and liver.⁷⁶ Changing to a diet low in iron and vitamin C may have been helpful in resolving these lesions. Congestive heart failure complicated by atrial fibrillation due to mitral valve insufficiency has been reported in a Pukeko.⁴ A number of ECGs of parrots with congestive heart failure have been documented by the primary author (Figures 27.10, 27.11, 27.19).

Spontaneous turkey cardiomyopathy (STC), and ascites associated with right ventricular failure (ARVF) in broilers have been well documented. The high incidence of cardiovascular failure in meat-type poultry is probably the result of genetic selection for rapid growth and high breast meat yield, with no attention to cardiovascular health and stress resistance. The practice of inbreeding certain species of companion birds for color or size variations could have a similar effect.

Ascites associated with right ventricular failure seems to be associated with the oxygen demand placed on the body. Ascites associated with right ventricular failure was first described at high altitudes, but it also occurs at low altitudes and is most common in rapidly growing broiler chicks, with an increased incidence in cold weather. The following pathophysiologic mechanism has been suggested for ARVF.⁴⁸ The relatively higher oxygen demand causes a hypoxemia, which in turn induces a polycythemia. With polycythemia, the blood is more viscous and more difficult to pump through the lungs. The increased workload results in right ventricular dilatation and hypertrophy. The resulting insufficiency of the right ventricular valve leads to RVF, with associated liver congestion and ascites. Right ventricular failure and ascites have also been reported as a result

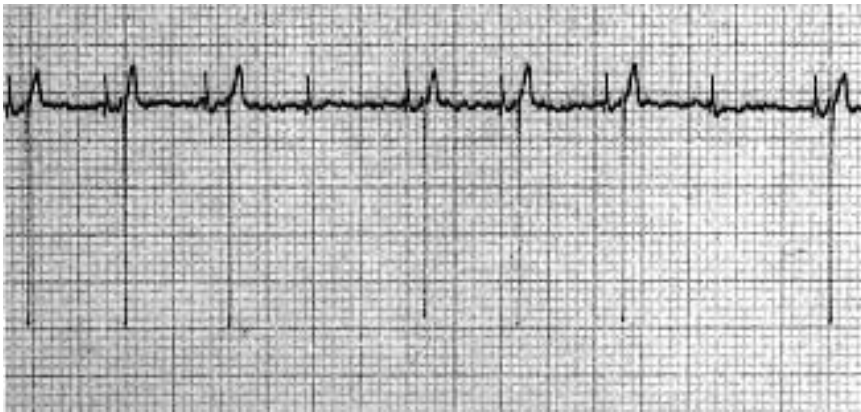

FIG 27.18 Normal lead III from a pigeon electrocardiogram showing Wenckebach block. The PR-interval becomes prolonged just prior to the omission of a QRS-complex.

of sodium toxicity. A moderate increase in dietary sodium for one week may cause congestive heart failure.^{48a}

Treatment

Once congestive heart failure has been diagnosed, the prognosis for long-term survival is guarded, because a specific therapy is not available. A significant prolongation of life, however, can be achieved by providing timely symptomatic treatment. Treatment of congestive heart failure in birds can best be accomplished with the loop diuretic furosemide. The dosage must be adjusted for the individual bird, but 1-2 mg/kg SID or BID is a general starting point. Response to therapy should be rapid and can be best monitored by weighing the patient daily to establish the degree of fluid loss. Dosages should be tapered down to the minimal effective dose, but continuous therapy is required to prevent recurrence of fluid retention.

Side effects of furosemide administration include hypovolemia and hypokalemia. The latter is especially important when diuretics are used together with cardiac glycosides, because these drugs may also lower plasma potassium concentrations. Hypokalemia may increase the frequency of rhythm disturbances induced by cardiac glycosides.

Cardiac glycosides are indicated in congestive heart failure, especially when accompanied by atrial fibrillation. Ventricular tachycardia may be a contraindication because digitalis may induce ventricular fibrillation in these cases. Cardiac glycosides increase the contractility of the heart muscle and delay conduction through the atrioventricular node that can be seen by prolongation of the PR-interval on the electrocardiogram. Arterial pressure, cardiac output and

stroke volume are increased, while venous pressure is decreased. A decrease of the heart rate can be seen due to improvement of the circulation and parasympathetic (vagal) stimulation. Signs of toxicity include cardiac arrhythmias and gastrointestinal signs.

Any type of arrhythmia may result from digoxin poisoning. Digoxin therapy should be discontinued immediately if arrhythmias develop, and a lower dose regimen should be established. Diuretic-induced hypokalemia may precipitate digoxin-induced arrhythmias. Only limited

information is available with regard to digoxin therapy in birds. Digoxin appears to have varying effects among different avian species and the therapeutic index is low. Digoxin pediatric drops, rather than digoxin tablets, should be used in birds to improve the accuracy of dosing. A dose of 0.02 mg/kg daily was considered safe and produced satisfactory plasma levels of digoxin in parakeets and sparrows.³⁵ A daily dose of 0.01 mg/kg successfully reduced right ventricular enlargement and ascites in chickens.² A dose of 0.05 mg/kg/day was considered safe and produced adequate blood plasma levels in Quaker Conures (Monk Parakeet).¹⁰⁰

Recently, angiotensin converting enzyme (ACE) inhibitors, which reduce the formation of angiotensin II, have gained considerable popularity for the treatment of congestive heart failure in man.^{10,15,74,79,81} These drugs, including captopril and enalapril, reduce plasma volume by interfering with the renin-angiotensin-aldosterone system, and should be used in combination with a diuretic. There are no reports of the use of these drugs for the treatment of congestive heart failure in birds, but it has been shown that inhibition of endogenous angiotensin II concentrations in quail by captopril can decrease natural water intake.⁹⁴

Vegetative Endocarditis

Endocarditis of the aortic and mitral valves may cause vascular insufficiency, lethargy and dyspnea. Valvular endocarditis is most common in birds with chronic infections (eg, salpingitis, hepatitis and bumblefoot) and has been reported in a large variety of avian species including Galliformes,^{7,31,69,73} Anseriformes,^{7,36} eagle,⁴⁴ emus,⁷⁰ curassow,⁷³ flamingo and a Blue and Gold Macaw.⁴² Frequently implicated bac-

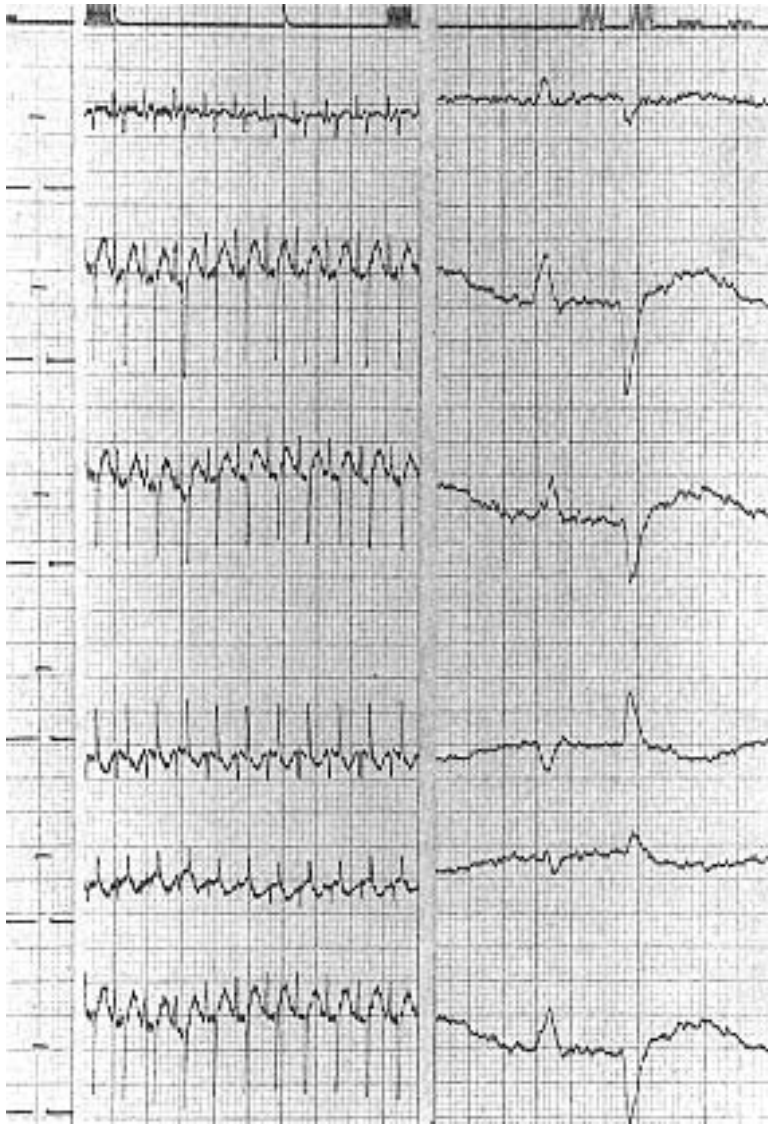

FIG 27.19 ECG of a 12-year-old Amazon parrot with congestive heart failure. From top to bottom: leads I, II, III, aVR, aVL and aVF. 1 cm = 1 mV; paper speed 25 mm/s and 200 mm/s.

Heart Rate: 320.

Rhythm: Normal sinus rhythm.

Axis: -110° (In this series of leads there is no true isoelectric lead. The two leads that are closest to being isoelectric are lead I [0.4 mV negative] and lead aVL [0.3 mV positive]. Lead aVF is perpendicular to lead I and negative and lead II is perpendicular to lead aVL and negative. The heart axis is slightly more negative than the average between -120° and -90° because the positive value of lead aVL is slightly more than the negative value of lead I.)

Measurements: P-wave = 0.7 mV, 0.02 s. PR-interval = 0.065 s. QRS-complex = 0.02 s, QS = 1.3 mV. T discordant, 0.5 mV. QT-interval = 0.1 s.

Electrocardiographic Diagnosis: P pulmonale and P mitrale are indicative of biatrial enlargement. Widening of the QRS-complex and lengthening of QT-interval are indicative of left ventricular enlargement. Axis deviation to -110° .

Clinical Findings: This bird was presented with dyspnea of at least four months' duration. The dyspnea had become progressively more severe for the few days before evaluation. Radiographs indicated cardiohepatomegaly. Ultrasonography revealed ascites and dilation of the hepatic veins. Total protein and protein electrophoresis were normal. Unsuccessful treatment with oxygen, gavage feeding, furosemide and digoxin was attempted. Postmortem findings confirmed cardiohepatomegaly and severe ascites. Histologic examination of the liver revealed fibrosis that was thought to have occurred secondary to right ventricular failure (courtesy of J. T. Lumeij).

TABLE 27.3 Clinical Signs Associated with Heart Disease

Congestive Heart Failure	Arrhythmia
<ul style="list-style-type: none"> ▪ Dyspnea ▪ Coughing ▪ Weakness ▪ Syncope ▪ Cachexia ▪ Reduced exercise tolerance ▪ Sudden death ▪ Edema and ascites 	<ul style="list-style-type: none"> ▪ Asymptomatic ▪ Dyspnea ▪ Coughing ▪ Weakness ▪ Syncope ▪ Sudden death

teria include streptococci, staphylococci, *E. coli*, *Pasteurella*, *Pseudomonas aeruginosa* and *Erysipelothrix rhusiopathiae*. In pigeons, trichomoniasis has been reported as a cause of valvular endocarditis.³¹

Lesions consist of yellow irregular masses on any of the heart valves. The disease is associated with bacteremia, and thromboembolisms may occur throughout the vasculature.^{31,36,69,70} Secondary lesions have been described in the liver, CNS, spleen, heart, lungs, kidneys, ischiatic artery and external iliac artery (Figure 27.20).^{36,70}

Any alteration in blood flow through the heart could predispose a bird to endocarditis. The initial damage to the heart valves that induces vegetative endocarditis is usually unknown. Factors that have been associated with endocardial or valvular lesions include chronic bacterial septicemia, frostbite, congenital lesions (that alter blood flow) and degenerative myocarditis.^{4,36,44,70,98}

Clinical Findings

Valvular endocarditis and vascular insufficiency are frequently associated with lethargy and dyspnea, although the clinical presentation can vary. A six-year-old Blue and Gold Macaw was presented with anorexia, tachypnea, mild dyspnea and weight loss. A mild systolic murmur, which could best be auscultated over the left pectoral muscles, was noted on physical examination. *Enterobacter cloacae* was isolated from the blood in pure culture. Vegetative endocarditis of the left AV valve was diagnosed (Figure 27.21).⁴²

Erysipelothrix rhusiopathiae was recovered from mitral and tricuspid valve lesions of a subclinical seven-year-old female swan that was found dead in her enclosure.³⁶

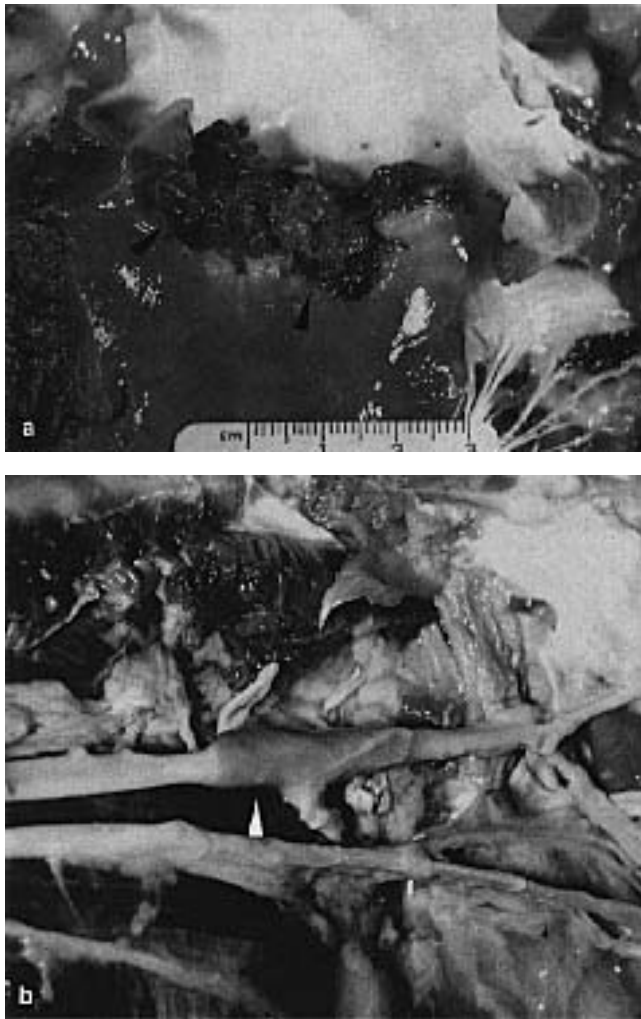

FIG 27.20 A four-year-old emu with a six-week history of lethargy, anorexia and inability to stand had a mild systolic murmur. Abnormal clinical pathology findings included an elevated AST (6000 IU/l) and anemia (PCV=27%). Electrocardiography revealed a heart rate = 120, P-wave = 0.3 mV, PR-interval = 150 mS, R-wave = 0.15 mV, S-wave = 1.3 mV, QRS-complex = 40 mS, mean electrical axis = -90° . Echocardiography indicated a large mass on the aortic valve. **a)** Staphylococcus was isolated from vegetative endocardial lesions (arrows). **b)** Ischemic infarcts were found in several large muscle masses, and a thrombus was present in the left external iliac artery (arrow) (courtesy of John Randolph, reprinted with permission⁷⁰).

A six-year-old curassow was presented with lethargy and a cool edematous left leg. Radiography revealed cardiomegaly and enlargement of a brachiocephalic artery. Abnormal clinicopathologic findings included heterophilia (60,000/l with toxic changes), and elevated plasma activities of LDH and CPK (4108 IU/l and 6,692 IU/l, respectively). Staphylococcus-induced lesions were found on the left AV valve. Septic thrombi were present in the left brachial artery.⁷³

Myocardial Diseases

Congenital Heart Disease

A list of common avian heart diseases and some of their etiologies are listed in Table 27.4. Chicken embryos are classic experimental animals to study teratologic effects of drugs on the heart. Various cardiovascular malformations can experimentally be induced, especially intraventricular septal defects. Spontaneous cardiovascular malformations like duplicitas cordis, multiplicatis cordis, ectopia cordis have been reported.³¹ Intraventricular septal defects are common, while foramen ovale persistence is of little clinical importance. Intraventricular septal defects are usually functionally closed, but in two percent of cases the condition is associated with congestive heart failure. Blood is shunted from left to right, which leads to right ventricular failure and ascites secondary to valvular insufficiency.

Acquired Diseases

In mammals, myocarditis can occur secondary to many common viral, bacterial, mycotic and protozoan infections. Cardiomyopathy has been associated with thyroid diseases, anemia, malnutrition, metabolic disorders, parasitic infections, pancreatitis, toxemias and neoplasia.²⁴ The pathogenesis of cardiomyopathy and myocarditis in birds is similar to that described in mammals.³¹ The liver and myocardium can be sites of excessive iron storage in birds with hemochromatosis. Experimental *E. coli* infections have been shown to cause myocarditis and pericarditis with marked electrocardiographic changes, including left axis deviation.³²

Fowl plague has been associated with myocardial lesions in a variety of avian species.⁶⁰ Myocarditis has been reported as a component of neuropathic gastric dilatation in psittacines.⁹⁷ Sarcocysts (muscle cysts containing bradyzoites, the asexual generation of *Sarcocystis* spp.) have been reported in the myocardium of a variety of avian species.^{23,55,66} A number of idiopathic degenerative conditions of the myocardium have been reported in gallinaceous birds.

Spontaneous turkey cardiomyopathy (STC, round heart disease, cardiohepatic syndrome) in turkey poults one to four weeks of age is characterized by marked dilatation of the right ventricle with extreme thinning of the ventricular wall.⁷⁵ Generally, ascites, hydropericardium and liver congestion are present.^{41,75} Although the major increase in heart size is caused by the right ventricular dilatation, there is also an increase in total mass of both ventricles, with

TABLE 27.4 Some Common Causes of Heart Lesions in Birds

Pericarditis	Myocarditis
<i>Listeria</i>	<i>Listeria</i>
<i>E. coli</i> septicemia	<i>E. coli</i> septicemia
<i>Chlamydia</i>	<i>Pasteurella</i>
<i>Salmonella</i>	<i>Chlamydia</i>
Reovirus (Galliformes)	Polyomavirus
Concurrent respiratory disease	Avian serositis virus
	<i>Sarcocystis</i>
Cardiomegaly	Neuropathic gastric dilatation
Polyomavirus	Selenium and vitamin E deficiencies
Hemochromatosis	
Epicarditis	Hydropericardium
<i>Salmonella</i>	Polyomavirus
<i>Pasteurella</i>	Reovirus (Galliformes)
	Furazolidone toxicity
	Genetics

a relatively greater increase in the left.⁴⁰ Lungs are generally congested and edematous.⁷⁵ Although the etiology of STC is unknown, it is clinically associated with rapid growth and hypoxic conditions (eg, low oxygen levels in the incubator and poor ventilation).^{47,47b} Lesions induced by feeding ducklings, chicks and turkey poults furazolidone (300 ppm of feed) are indistinguishable from those described with STC.^{18,47,72}



FIG 27.21 Valvular endocarditis on the left atrioventricular valve (arrows) from a Blue and Gold Macaw (courtesy of Ramiro Issaz, reprinted with permission⁴²).

Myocardial degeneration (round heart disease) of unknown etiology has been described in backyard poultry. The morbidity is very low, but mortality may reach 50%. Lesions consist generally of an enlarged and yellowish heart. A few affected birds may have an excess of gelatinous fluid in the pericardial sac or peritoneal cavity.^{69,75} The disease should not be confused with STC.

Vitamin E and selenium deficiencies are well known as causes for cardiomyopathy in gallinaceous birds.⁷⁸ Selenium and vitamin E deficiencies have also been suggested as causes for myocardial and skeletal muscle degeneration in ratites less than six months old that died after a brief period of depression (see Chapter 48). Histologic lesions in the heart of these birds were similar to those reported in poultry with vitamin E and selenium deficiencies.⁷¹ Vitamin E and selenium deficiencies have also been suggested as causes of myocardial degeneration in cockatiels. Affected birds typically have increased activities of SGOT and CPK, decreased heart tone and an increase in pericardial fluid.³⁸

Various benign and malignant primary myocardial tumors arising from connective tissue or from muscle have been reported occasionally (see Chapter 25).³¹

Ruptures of the myocardium may occur secondary to degenerative, inflammatory or neoplastic conditions of the myocardium or aneurysms of the myocardial vessels (see Color 48).³¹ Myocardial infarctions may result from embolisms originating from valvular endocarditis or heavy metal poisoning.^{80,86} In White Carneaux Pigeons, myocardial infarcts have been reported after ulceration and embolism of atheromas in the aortic trunk.³¹

All conditions that lead to cardiomyopathy or myocarditis may result in increased myocardial irritability and cardiac arrhythmias that can be detected by ECG. Radiographs may reveal cardiomegaly (Figure 27.22). Electrocardiography has been shown to be effective for diagnosing both spontaneous and furazolidone-induced cardiomyopathy.^{40,46} Characteristic changes include a right axis deviation from negative to positive, ie, from an average of -85° (range -60° to -120°) to an average of 70° (range 32° to 95°).⁴¹ The amplitude of the P-wave is increased and the T-wave is negative in leads I, II and III. Similar ECG findings have been reported in psittacine birds with cardiomyopathy.⁶³

Treatment of myocardial disease should be aimed at the primary cause. Furthermore, symptomatic treat-

ment is indicated. Digoxin can be used when cardiac output is diminished due to myocardial disease, but is contraindicated when persistent ventricular arrhythmias are present. Digoxin treatment should be discontinued if the severity of an arrhythmia increases.

■ Epicardial and Pericardial Diseases³¹

Pericardial effusion is a common finding in birds. The accumulated fluid may be a result of cardiac or systemic disease and may be of an inflammatory or noninflammatory nature (see Color 14). Pericardial effusion may be part of generalized ascites. Transudates can occur with congestive heart failure and hypoproteinemia. Exudates may be present in a variety of infectious diseases. Fibrinous pericarditis is most common and may lead to adhesions of the epicardium to the pericardium and to constrictive heart failure (see Color 14). A serofibrinous pericarditis may occur in conjunction with a variety of bacterial (eg, *E. coli*, *Streptococcus* spp., *Listeria*, *Salmonella*) and viral (eg, reovirus in Galliformes, polyomavirus infections in Psittaciformes) diseases, and can also be seen in chlamydiosis and mycoplasmosis. Occasionally tuberculous or mycotic pericarditis can be encountered. *Pericarditis urica* may occur in birds with visceral gout (see Color 21). Hemopericardium may be the result of puncture of the epicardium by a foreign body, iatrogenic puncture of the heart, cardiac tumors, rupture of the left atrium or myocardial rupture.

Pericardial effusion may eventually result in heart failure. When a pericardial effusion develops rapidly, the circulatory system will not have time to compensate for the reduced cardiac output, and acute death occurs from cardiac tamponade.

Diagnostic techniques that may be of use in diagnosing pericardial effusion include radiography, electrocardiography, ultrasonography and endoscopy (Figure 27.23). Enlargement of the cardiac silhouette on radiographs may be caused both by cardiomegaly and pericardial effusion, and other techniques are needed to differentiate between these conditions. Ultrasonography is a useful method to demonstrate a pericardial effusion. Electrocardiography may reveal a low voltage ECG. Marked changes in the electrocardiogram, including left axis deviation, have been reported in *E. coli*-induced pericarditis and myocarditis in chickens.³²



FIG 27.22 An adult male duck was presented for dyspnea, coughing and syncope. The clinical signs were exaggerated by mild exercise. Radiographs indicated severe cardiomegaly. ECG and ultrasound diagnostics were refused. Other radiographic findings included a large amount of grit in the ventriculus and irregular mineral densities in the medullary canal of the femurs.

Fluid for bacteriology, cytology and clinical chemistries can be collected from the pericardial sac, using endoscopy (see Chapter 13). Treatment for pericardial effusion should be both symptomatic and aimed at treating the underlying condition (eg, antibiotics in bacterial pericarditis). Symptomatic treatment can be attempted with furosemide. If sufficient quantities of nonserosanguinous pericardial fluid cannot be removed by conventional means to avoid the occurrence of cardiac tamponade, then it is necessary to create a surgical window in the pericardium.²⁴ This technique was used successfully in an African Grey Parrot presented with congestive heart failure and idiopathic pericardial effusion.

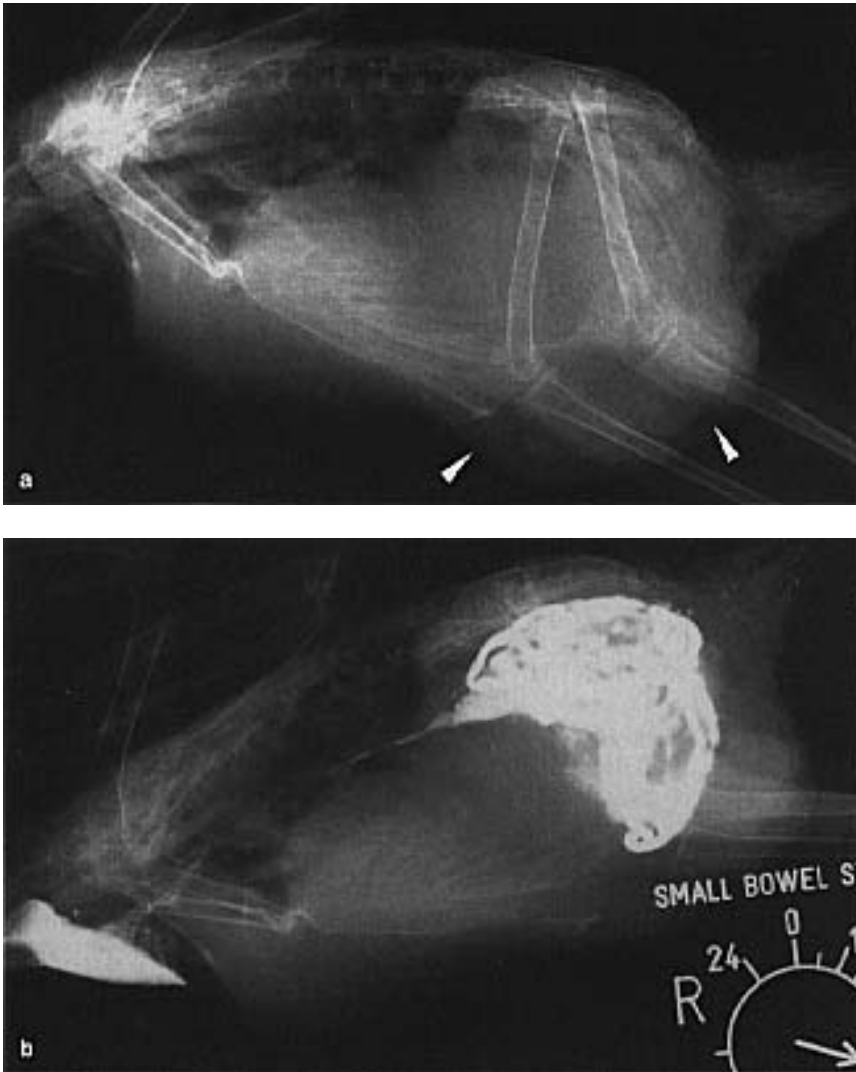

FIG 27.23 An adult Amazon parrot was presented for emaciation (254 g), a swollen abdomen and passing whole seeds. The referring veterinarian diagnosed NGD based on survey radiographs and clinical findings. Survey radiographs indicated a diffuse soft tissue density in the thorax and abdomen. Note the distension (arrow) of the abdominal wall. A barium contrast study indicated that the proventriculus was being displaced dorsally, and the intestinal tract was being displaced dorsally and caudally by an abdominal mass (suspected to be the liver). The heart was also considered to be enlarged, and the nondistinct edge of the cardiac silhouette was suggestive of pericardial effusion. Ultrasound confirmed pericardial effusion and hepatomegaly.

■ Atherosclerosis

Atherosclerosis can be defined as a diffuse or local degenerative condition of the internal and medial tunics of the wall of muscular and elastic arteries. The degenerative changes include proliferation of smooth muscle cells, deposition of collagen and proteoglycans and deposition of cholesterol (esters).⁴⁵ Calcium deposits may sometimes be encountered. The lesions can macroscopically be identified by

thickening and yellow discoloration of the arterial wall (see Color 14).

Atherosclerosis has been reported in many avian orders, but Psittaciformes (parrots)^{27,45} and Anseriformes (ducks and geese)²⁷ appear to be particularly susceptible. Amazon parrots seem to be specifically prone to atherosclerosis, and age appears to be a risk factor.⁴⁵ Ciconiiformes (flamingos, herons, storks), Falconiformes (vultures, falcons, eagles), Galliformes (pheasants, turkeys, fowl), Gruiformes (cranes), Columbiformes (pigeons), Cuculiformes, Coraciiformes, and Piciformes (toucans) are moderately susceptible. Atherosclerosis has also been seen in other species such as ostriches, penguins, cormorants, free-ranging owls, and various Passeriformes, including birds of paradise.^{27,62,65} In a retrospective study involving 12,072 companion and aviary birds, atherosclerosis was detected in 53 birds of six orders (Table 27.5).⁴⁵

Pathogenesis

In man, atherosclerosis of the coronary arteries is a major source of morbidity and mortality in affluent societies, and elevated serum lipids (cholesterol, triglycerides, low-density lipoproteins), hypertension and exposure to cigarette smoke are important risk factors.

The accumulation of pathogenic material in the arterial wall has been explained by the insudative theory.¹⁴ Normally a transfer of plasma proteins occurs through the arterial wall with subsequent removal from the

outer coats by lymphatic vessels. During this process of permeation, fibrinogen and very low density lipoproteins are selectively entrapped in the connective tissue of the arterial wall. Their presence stimulates reactive changes that give rise to the production of atherosclerotic lesions. Variations in vascular permeability and arterial blood pressure can explain the preference of atherosclerotic lesions for certain areas of the arterial system.

TABLE 27.5 Retrospective Study of Avian Atherosclerosis⁴⁵

Order	Number Affected	Anatomic Location
Psittaciformes	43	aorta (34) myocardial vessels (8) brachiocephalic trunk (7) splenic arteries (5) pulmonary artery (3)
Falconiformes	6	aorta (6) minor lesions in other vessels
Piciformes	1	aorta
Passeriformes	1	aorta
Strigiformes	1	aorta
Struthioniformes	1	mesenteric artery

In man, systemic hypertension is known to accelerate atherosclerotic diseases and atherosclerotic lesions are often seen in high pressure areas of the arterial system. Atherosclerosis in the pulmonary arteries is rare and seen only with pulmonary hypertension.

In birds, atherosclerotic lesions are usually found in the brachiocephalic trunk and abdominal aorta (Figure 27.24). Lesions in the internal carotid arteries also occur with some frequency. Atherosclerotic lesions in the coronary artery are not as common in birds as in man, but have been reported.⁴⁵ Atherosclerotic lesions have not been described in the brain, and lesions in the pulmonary artery are rare.

The risk factors associated with development of atherosclerosis in birds have been insufficiently studied;

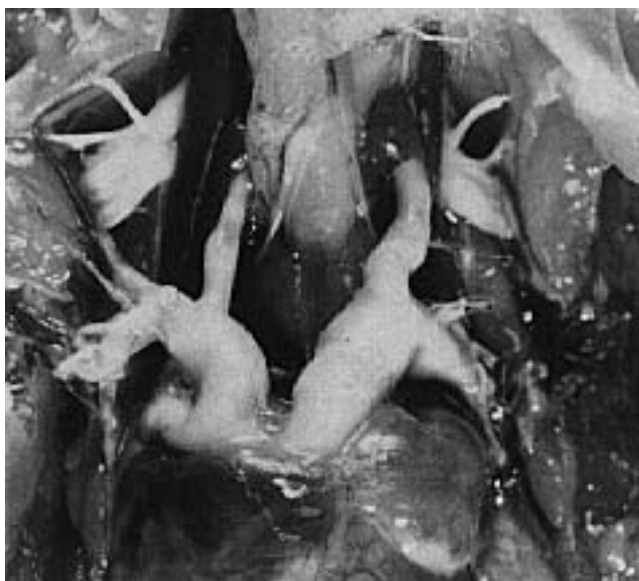

FIG 27.24 Atherosclerosis can be macroscopically identified by thickening and yellow discoloration of the arterial wall. Note the irregular margins to the great vessels in this 20-year-old rosella.

however, at least three of the risk factors that occur in humans (ie, obesity, high-fat diets and exposure to cigarette smoke) frequently occur in companion birds. In one study of birds from a zoological collection, the incidence of atherosclerosis was higher in females and carnivores than in males and granivores.⁶⁵ Free-ranging turkeys from colder environments have a higher incidence of atherosclerosis than birds from warmer environments, suggesting that cold stress may play a role in the pathogenesis of this disease.⁵⁴

In one study, 86% of the Amazon parrots with atherosclerosis were over five years;⁴⁵ however, in another study an age or species predilection to atherosclerosis among zoo and aviary birds was not found to occur. Atherosclerosis and congestive heart failure should be considered in any geriatric patient with lethargy, dyspnea, coughing or abdominal swelling (ascites).⁶⁵

Marek's disease virus infections of arterial smooth muscle cells induce an altered lipid metabolism that can result in the accumulation of phospholipids, free fatty acids, cholesterol and cholesterol esters.^{26,34} White Carneaux Pigeons that are genetically predisposed to atherosclerosis are extensively used in studies of this disease.⁷⁷

Clinical Changes

Clinical signs associated with atherosclerosis are caused by decreased blood flow through the affected vessels and plaque-induced thrombi that cause vascular accidents.

Clinical signs of atherosclerosis are rarely reported in birds, and the condition is often associated with sudden death; however, subtle and intermittent signs that include dyspnea, weakness and neurologic signs may be present. Regurgitation from an undocumented cause is common. Blood chemistry may reveal elevated plasma cholesterol. Radiologic examination may reveal an increased density and size of the right aortic arch. Nodular densities cranial to the heart may be caused by large arteries with atherosclerotic changes that are seen end on.⁴⁵

Galliformes and Anseriformes may die acutely from dissecting aneurysms that result in aortic rupture secondary to hypertension and atherosclerosis. The abdominal aorta and aortic arch are the two vessels that are most frequently affected. In some species, males tend to have more severe lesions in the abdominal aorta, while females most frequently develop lesions in the aortic arch.

Atherosclerosis was diagnosed at necropsy in a seven-year-old female Blue-fronted Amazon with a two-month history of regurgitation and stupor. Lesions were noted over the entire length of the aorta and brachiocephalic trunk. The lumen of the carotid arteries were reduced up to 95%. Lesions were noted also in the small arteries in the epicardium, myocardium and the renal artery. Clinicopathologic findings were unremarkable. Radiographs indicated a prominent aortic arch and pulmonary vein.⁴⁵

Atherosclerosis involving the aorta, brachiocephalic trunk and axillary arteries was described in an 18-year-old male African Grey Parrot with weight loss, dyspnea and rhinitis. A concomitant respiratory bacterial infection was also present.⁴⁵

Coronary atherosclerosis was documented in 75% of the birds that were necropsied in one zoological collection. The most severe vascular lesions occurred in birds that also had thyroid abnormalities.⁶⁵ A few birds, including an ostrich and a hornbill with atherosclerosis, showed signs of chronic weakness prior to death. Lesions in parrots have been described most frequently in the aorta and its major branches.¹³

Aortic Rupture

Aortic rupture in turkeys is a condition associated with fatal hemorrhage from a ruptured aorta. The disease is especially common in male turkeys between 6 and 24 weeks of age with the highest mortality seen between three and four months. The location between the external iliac and ischiatic arteries is the most common site, but the aorta may rupture at another site just dorsal to the heart. In turkey hens a rupture of the left atrium may occur. The precise etiology is unknown, but the disease is associated with hypertension, degenerative changes of the aorta wall (atherosclerosis, qv), copper deficiency and high levels of protein and fat in the diet (see Color 48). Similar lesions may be induced in turkeys by ingestion of the sweet pea (*Lathyrus odoratus*).^{48,75}

Product Mentioned in the Text

- a. Platinum Subdermal Electrodes Type E2. Grass Instrument Company, Quincy MA.

References and Suggested Reading

1. **Altman RB, Miller MS:** Effects of anesthesia on the temperature and electrocardiogram of birds. *Proc Assoc Zoo Vet*, 1979, pp 61-62.
2. **Alvarez Maldonado MVZ:** Report preliminar. Digitalizacion en pollos de engorda como metodo preventivo en el sindrome ascitico. *Proc 35th West Poul Dis Conf*, 1986.
3. **Andersen HT:** Hyperpotassemia and electrocardiographic changes in the duck during prolonged diving. *Acta Physiol Scand* 63:292-295, 1975.
4. **Beehler BA, Mantali RJ, Bush M:** Mitral valve insufficiency with congestive heart failure in a Pukeko. *J Am Vet Med Assoc* 177:934-937, 1980.
- 4a. **Blanco JM:** Avian electrocardiography: A contribution for the practitioner. *Proc Europ Assoc Avian Vet*, Utrecht, 1993, pp 137-154.
5. **Bolton GR:** Handbook of Canine Electrocardiography. Philadelphia, WB Saunders Co, 1975.
6. **Boulianne M, et al:** Cardiac muscle mass distribution in the domestic turkey and relationship to electrocardiogram. *Avian Dis* 36:582-589, 1992.
7. **Bricker JM, Saif YM:** Erysipelas. In Calnek BW, et al (eds): Diseases of Poultry. Ames, Iowa State University Press, 1991, pp 247-257.
8. **Buchanan F:** The frequency of the heart beat and the form of the electrocardiogram in birds. *Proc Physiol Soc*, J Physiol 38:lxii-lxvi, 1909.
9. **Calnek BW, et al (eds):** Diseases of Poultry. Ames, Iowa State University Press, 1991.
10. **Captopril Multicenter Research Group:** A placebo-controlled trial in refractory chronic congestive heart failure. *J Am Coll Cardiol* 2:755-763, 1983.
11. **Carler CW, Drury AN:** Heart block in white fed pigeons. *J Physiol* 68:i-ii (Proc), 1929.
12. **Castellanos A, Meyerburg RJ:** The resting electrocardiogram. In Hurst JE (ed): The Heart 6th ed. New York, McGraw Hill Book Company, 1986, pp 206-229.
13. **Coffin DL:** Angell Memorial Parakeet and Parrot Book. Boston, Angell Memorial Veterinary Hospital, 1953.
14. **Coltart DJ:** Ischaemic heart disease. In Scott RB (ed): Price's Textbook on the Practice of Medicine 12th ed. Oxford, Oxford University Press, 1978, pp 787-802.
15. **Consensus Trial Study Group:** Effects of enalapril on mortality in severe congestive heart failure. *N Engl J Med* 316:1429-1435, 1987.
16. **Crawley RR, Ernst JV, Milton JL:** Sarcocystis in a bald eagle. *J Wildl Dis* 18:253-255, 1992.
17. **Czarnecki CM, Good AL:** Electrocardiographic technique for identifying developing cardiomyopathies in young turkey poults. *Poult Sci* 59:1515-1520, 1980.
18. **Czarnecki CM:** Cardiomyopathy in turkeys (a review). *Comp Biochem Physiol* 77A:591-598, 1984.
19. **Domingo M et al:** Heart rupture and haemopericardium in capercaillie (*Tetrao urogallus*) reared in captivity. *Avian Pathol* 20:363-366, 1991.
20. **Dorrestein GM, Van der Hage MH:** Veterinary problems in mynah birds. *Proc Assoc Avian Vet*, 1988, pp 263-274.
21. **Edjethadi M, Rezakhani A, Szabuniewicz M:** The electrocardiogram of the Buzzard (*Buteo*). *Zentralblatt fuer Veterinaermedizin A* 24:597-600, 1977.
22. **Ensley PK, Hatkin J, Silverman S:** Congestive heart failure in a greater hill mynah. *J Am Vet Med Assoc* 175:1010-1013, 1979.
23. **Erickson AB:** Sarcocystis in birds. *Auk* 57:514-519, 1940.
24. **Etfinger SJ, Suter PF:** Canine Cardiology. Philadelphia, WB Saunders Co, 1970.
25. **Fabricant CG, et al:** Virus-induced atherosclerosis. *J Exp Med* 148:335-340, 1978.
26. **Fabricant CG, et al:** Herpesvirus infection enhances cholesterol and cholesteryl ester accumulation in cultured arterial smooth muscle cells. *Am J Pathol* 105:176-184, 1981.
27. **Fiennes RN T-W-:** Diseases of the cardiovascular system. In Petrak ML (ed): Diseases of Cage and Aviary Birds 2nd ed. Philadelphia, Lea & Febiger, 1982, pp 422-431.
28. **Gabraschanski P, Georgiev Ch:** Untersuchungen ueber die Perikarditis, 'Rundherzkrankheit' und Endokarditis bei den Truthuehnern unter besonderer Beruecksichtigung der Veraenderungen im Elektrokardiogram. *Deutsche tieraerztliche Wochenschrift* 78:389-412, 1971.
29. **Gaskin JM, Homer BL, Eskelund KH:** Preliminary findings in avian viral serositis, a newly recognized syndrome in psittacines. *J Assoc Avian Vet* 5:27-34, 1991.
30. **Good AL, Czarnecki CM:** The production of cardiomyopathy in turkey poults by the oral administration of furazolidone. *Avian Dis* 24:980-988, 1980.
31. **Gratzl E, Koehler H:** Spezielle Pathologie und Therapie der Gefuegelkrankheiten. [Pathology and Therapy of Poultry Diseases]. Stuttgart, Ferdinand Enke Verlag, 1968, pp 1028-1038.
32. **Gross WB:** Electrocardiographic changes of *Escherichia coli* infected birds. *Am J Vet Res* 27:1427-1436, 1966.
33. **Grubb B:** Allometric relations of cardiovascular function in birds. *Am J Physiol* 245:H567, 1983.
34. **Hajjar PP et al:** Virus-induced atherosclerosis. *Am J Pathol* 122:62-70, 1986.
35. **Hamlin RL, Stalnaker PS:** Basis for use of digoxin in small birds. *J Vet Pharmacol Therap* 10:354-356, 1987.
36. **Harari J, Miller D:** Ventricular septal defect and bacterial endocarditis in a whistling swan. *Avian Pathol* 183:1296-1297, 1983.
37. **Harrison GJ et al:** A clinical comparison of anesthetics in domestic pigeons and cockatiels. *Proc Assoc Avian Vet*, Boulder, 1985, pp 7-22.
38. **Harrison GJ:** Preliminary work with selenium vitamin E responsive conditions in cockatiels and other psittacines. *Proc Assoc Avian Vet*, 1986, pp 257-262.
39. **Hill JR, Goldberg JM:** P-wave morphology and atrial activation in the domestic fowl. *Am J Physiol* 239:R483, 1980.
40. **Hunsaker WG:** Round heart disease in four commercial strains of turkeys. *Poult Sci* 50:1720-1724, 1971.
41. **Hunsaker WG, Robertson A, Magwood SE:** The effect of round heart disease on the electrocardiogram and heart weight of turkey poults. *Poult Sci* 50:1712-1720, 1971.
42. **Isaza R, Buergeit C, Kolias GV:** Bacteremia and vegetative endocarditis associated with a heart murmur in a blue and gold macaw. *Avian Dis* 36:1112-1116, 1992.

43. **Ihurri SJ, Ringer RK:** The effect of dietary PCB on the electrocardiogram of cockerels. *IRCS Med Sci* 7:254, 1979.
44. **Jessup DA:** Valvular endocarditis and bacteremia in a bald eagle. *Med Vet Pract* 61:49-51, 1980.
45. **Johnson JA, et al:** Atherosclerosis in psittacine birds. *Proc Assoc Avian Vet, New Orleans*, 1992, pp 87-93.
46. **Jordan KA, et al:** Cardiography of turkeys with round heart involvement. Conference on Engineering in Medicine and Biology. Houston, Texas, 1968 (November 18-21), # 407.
47. **Julian RJ:** Poisons and toxins. In Calnek BW et al (eds): *Diseases of Poultry* 9th ed. Ames, Iowa State University Press, 1991, pp 863-915.
48. **Julian RJ:** Cardiovascular disease. In Jordan FTW (ed): *Poultry Diseases* 3rd ed. London, Ballière Tindall, 1990, pp. 330-353.
- 48a. **Julian RJ:** The effect of increased sodium in the drinking water on right ventricular hypertrophy, right ventricular failure and ascites in broiler chickens. *Avian Pathol* 16:61-71, 1987.
- 48b. **Julian RJ, et al:** Effects of hypoxia and diet on spontaneous turkey cardiomyopathy (round heart disease). *Avian Dis* 36:1043-1047, 1992.
49. **Kahn RH:** Das Vogel-Ekg. *Arch. fuer den Gesamten Physiologie* 162:67-93, 1915.
50. **King AS, McLelland J:** Birds. Their Structure and Function. London, Ballière Tindall, 1984, pp 214-228.
51. **Kish B:** Electrocardiographic studies in seagulls. *Exp Med Surg* 7:103-124, 1949.
52. **Kollias GV:** Drug-induced cardiomyopathy in birds. *Proc Assoc Avian Vet*, 1986, p 263.
53. **Krista LM, et al:** Comparison of electrocardiograms of hypertensive and hypotensive male turkeys. *Poult Sci* 49:700-703, 1970.
54. **Krista LM, McQuire JA:** Atherosclerosis in coronary, aortic, and sciatic arteries from wild male turkeys. *Am J Vet Res* 49:1582-1588, 1988.
55. **Latimer KS, Perry RW, Mo IA, et al:** Myocardial sarcocystosis in a grand euclectus parrot and a moluccan cockatoo. *Avian Dis* 34:501-505, 1990.
56. **Lumeij JT, Stokhof AA:** Electrocardiogram of the racing pigeon (*Columba livia domestica*). *Res Vet Sci* 38:275-278, 1985.
57. **Lumeij JT:** Clinical electrocardiography in racing pigeons. *Proc V. Tagung ueber Vogelkrankheiten der Deutsche veterinaermedizinische Gesellschaft eV, München*, 1986, pp 19-33.
58. **Lumeij JT:** Anesthetic fatalities in goshawks. *Proceedings V. Tagung ueber Vogelkrankheiten der Deutsche veterinaermedizinische Gesellschaft eV, München*, 1986, pp 201-207.
59. **Magwood SE, Bray DF:** Diseases conditions of turkey poults characterized by enlarged and rounded hearts. *Can J Comp Med Vet Sci* 26:268-272, 1962.
60. **McKenzie BE, Will JA:** Electrocardiographic changes following influenza infection in turkeys. *Avian Dis* 16:308-318, 1972.
61. **McKenzie BE, Will JA, Hardie A:** The electrocardiogram of the turkey. *Avian Dis* 15:737-744, 1971.
62. **McOrist S:** Some diseases of free living Australian birds. *ICBP publication No 10*, 1989.
63. **Miller MS:** Electrocardiography. In Harrison GJ, Harrison LR (eds): *Clinical Avian Medicine and Surgery*. Philadelphia, Saunders, 1986, pp 286-292.
64. **Mitchell BW, Brugh M:** Comparison of electrocardiograms of chickens infected with viscerotropic velogenic Newcastle disease virus and virulent avian influenza virus. *Am J Vet Res* 43:2274-2278, 1982.
65. **Mueller RW, Rapley WA, Mehren KG:** Pathology of thyroid disease and arteriosclerosis in captive wild birds. In Montali RJ (ed): *Comparative Pathology of Zoo Animals*. Washington DC, Smithsonian Institution Press, 1980, pp 523-527.
66. **Munday BL, Hartley WJ, Harrigan KE, et al:** Sarcocystis and related organisms in Australian wildlife. *J Wildl Dis* 15:57-73, 1979.
67. **Nap A, Lumeij JT, Stokhof AA:** Electrocardiogram of the African grey (*Psittacus erithacus*) and Amazon (*Ama-zona spp.*) parrot. *Avian Pathol* 21:45-53, 1992.
- 67a. **Odom TW, Hargis BM, Lopez CC, et al:** Use of electrocardiographic analysis for investigation of ascites syndrome in broiler chickens. *Avian Dis* 35:738-744, 1991.
68. **Orr JP et al:** Ascites in broiler chickens. *Can Vet J* 27:99-100, 1986.
69. **Peckham MC:** Vices and miscellaneous diseases. In Hofstad MS, et al (eds): *Diseases of Poultry* 7th ed. Ames, Iowa State University Press, 1978, pp 847-893.
70. **Randolph JR, Moise S, Graham DL, et al:** Bacterial endocarditis and thromboembolism of a pelvic limb in an emu. *J Am Vet Med Assoc* 185:1409-1410, 1984.
71. **Rea M:** Degenerative myopathy in ratites. *Proc Assoc Avian Vet, New Orleans*, 1992, pp 328-335.
72. **Reed WM et al:** Furazolidone-associated cardiomyopathy in two Indiana flocks of ducklings. *Avian Dis* 31:666-672, 1987.
73. **Reavill DR:** Septic thrombosis in a great curassow. *Proc Assoc Avian Vet, New Orleans*, 1992, pp 174-176.
75. **Riddel C:** Developmental, metabolic, and miscellaneous disorders. In Calnek BW et al (eds): *Diseases of Poultry*. Ames, Iowa State University Press, 1991, pp 827-862.
76. **Rosenthal K, Stamoulis M:** Congestive heart failure due to mitral regurgitation in an Indian Hill mynah bird. *Proc Assoc Avian Vet, New Orleans*, 1992, pp 171-173.
77. **Santerre RF, Wight TN, Smith SC, et al:** Spontaneous atherosclerosis in pigeons. *Am J Pathol* 67:1-22, 1972.
78. **Scott ML et al:** Selenium responsive myopathies of myocardium and smooth muscle in the young poult. *J Nutr* 91:573-583, 1967.
79. **Sharpe DN et al:** Enalapril in patients with chronic heart failure: A placebo-controlled randomized double-blind study. *Circulation* 70:271-278, 1984.
80. **Sileo L, Jones RN, Hatch RC:** The effect of ingested lead shot on the electrocardiogram of Canada geese. *Avian Dis* 17:308-313, 1973.
81. **SOLVD Investigators:** Effect of enalapril on survival in patients with reduced left ventricular ejection fractions and congestive heart failure. *N Engl J Med* 325:293-302, 1991.
82. **Steel RGD, Torrie JH:** Principles and Procedures of Statistics. New York, McGraw-Hill Book Co, 1960.
83. **Sturkie PD:** The electrocardiogram of the chicken. *Am J Vet Res* 10:168-175, 1949.
84. **Sturkie PD:** Effects of changes in position of the heart of the chicken on the electrocardiogram. *Am J Physiol* 154:251-257, 1949.
85. **Sturkie PD:** Abnormal electrocardiograms of chickens produced by potassium deficiency and effects of certain drugs on the abnormalities. *Am J Physiol* 162:538-544, 1950.
86. **Sturkie PD:** Effects of cadmium on electrocardiogram, blood pressure, and hematocrit of chickens. *Avian Dis* 117:106-110, 1973.
87. **Sturkie PD (ed):** *Avian Physiology* 4th ed. New York, Springer, 1986, pp 167-191.
88. **Sturkie PD, et al:** The effects of dietary deficiencies of vitamin E and the B-complex vitamins on the electrocardiogram of chickens. *Am J Vet Res* 15:457-462, 1954.
89. **Sturkie PD:** Effects of acute thiamine deficiency on the electrocardiogram of the chick. *Poult Sci* 31:648-650, 1952.
90. **Sturkie PD:** Further studies on potassium deficiency on the electrocardiogram of chickens. *Poult Sci* 31:648-650, 1952.
91. **Sturkie PD:** Heart. In Sturkie PD (ed): *Avian Physiology*. New York, Springer Verlag, 1986, pp 130-190.
92. **Sturkie PD:** Role of estrogen on sex differences of the electrocardiogram of the chicken. *Proc Soc Exp Biol Med* 94:731-733, 1957.
93. **Szabuniewicz M, McCrady JD:** The electrocardiogram of the chicken. *Southwestern Veterinarian* 20:287-294, 1967.
94. **Takei Y, Kobayashi H:** Hormonal regulation of water and sodium intake in birds. In Wada M, Ishii S, Scanes CG (eds): *Endocrinology of Birds. Molecular to Behavioral*. Berlin, Springer Verlag, 1990, pp 171-186.
95. **Taylor M:** Polycythemia in the blue and gold macaw. *Proc Assoc Avian Vet*, 1987, pp 95-104.
96. **Tilley LP:** Essentials of Canine and Feline Electrocardiography. London, CV Mosby, 1979.
97. **Vice CA Cazayoux:** Myocarditis as a component of psittacine proventricular dilatation syndrome. *Avian Dis* 36:1117-1119, 1992.
98. **Wallach JD, Flieg GM:** Frostbite and its sequelae in captive exotic birds. *J Am Vet Med Assoc* 155:1035-1038, 1969.
99. **Warzecha M:** Physiological arrhythmias in pigeons. *Proc Europ Assoc Avian Vet, Utrecht*, 1993, pp 367-387.
- 99a. **Webb DM, Denicola DB, Van Vleet JF:** Serum chemistry alterations, including creatine kinase isoenzymes, in furazolidone toxicosis of ducklings: Preliminary findings. *Avian Dis* 35:662-667, 1991.
100. **Wilson RC, Zenoble RD, Horton CR, et al:** Single dose digoxin pharmacokinetics in the quaker conure. *J Zoo Wildl Med* 20:432-434, 1989.
101. **Zenoble RD, Graham DL:** Electrocardiography in the parakeet and parrot. *Comp Cont Ed Prac Vet* 3:711-716, 1981.